

MODEL NO.	PACKAGING
148-0701-301	ONE PCS PER BAG

REV	ECO	DATE
001	ECO-17-003	12/18/2017

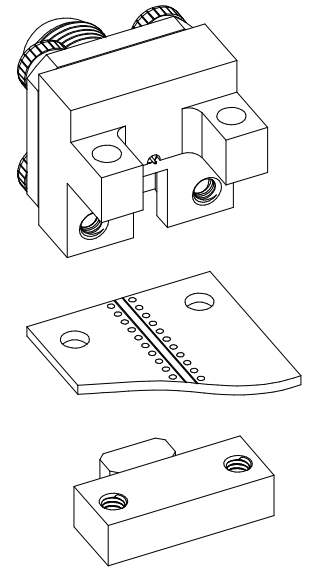
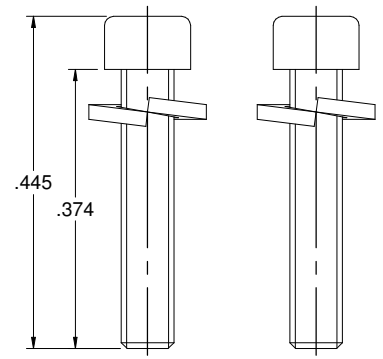
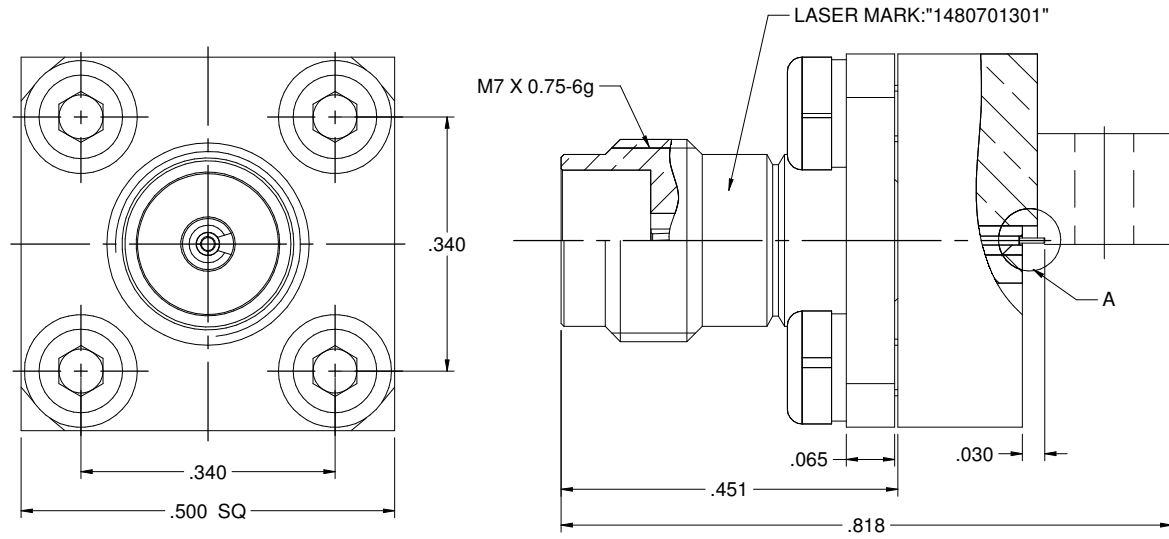
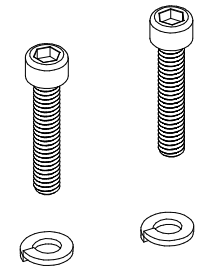
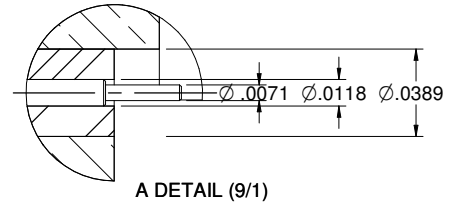

NOTES: UNLESS OTHERWISE SPECIFIED

1. MATERIAL & FINISH:
 - 1.1 BODY: NICKEL PLATED BRASS
 - 1.2 CONTACT PIN : GOLD PLATED BERYLLIUM COPPER
 - 1.3 INSULATOR: PTFE WHITE
 - 1.4 BOLT & WASHER: STAINLESS STEEL
2. ELECTRICAL:
 - 2.1 IMPEDANCE: 50 OHMS
 - 2.2 FREQUENCY RANGE: 0-67 GHz
 - 2.3 VOLTAGE STANDING WAVE RATIO: 1.2 MAX
 - 2.4 CONTACT RESISTANCE:
 - 2.4.1 CENTER CONTACT: 6 MILLIOHM MAX
 - 2.4.2 OUTER CONTACT: 2.5 MILLIOHM MAX
 - 2.5 INSULATION RESISTANCE: 5000 MOHM MIN
 - 2.6 DIELECTRIC WITHSTANDING VOLTAGE: 500 VRMS
3. MECHANICAL:
 - 3.1 ENGAGEMENT/DISENGAGEMENT FORCE: 0.23 NM MAX
 - 3.2 CONTACT RETENTION: 20N MIN
 - 3.3 DURABILITY: 500 CYCLES MIN
4. ENVIRONMENT:
 - 4.1 THERMAL SHOCK: MIL-STD-202, METHOD 107, CONDITION B.
 - 4.2 OPERATING TEMPERATURE: -55 TO 125°C
 - 4.3 SALT SPRAY: MIL-STD-202, METHOD 101, CONDITION B
 - 4.4 SHOCK: MIL-STD-202, METHOD 213, CONDITION I
 - 4.5 VIBRATION: MIL-STD-202, METHOD 204, CONDITION D
 - 4.6 MOISTURE RESISTANCE: MIL-STD-202, METHOD 106

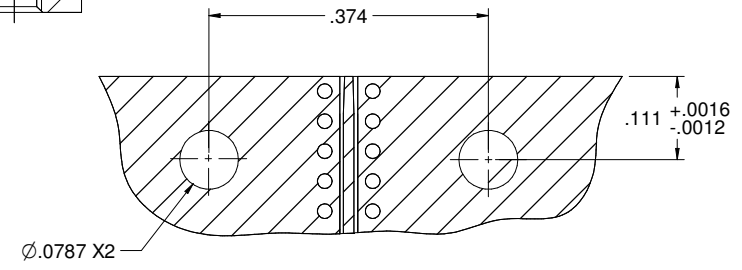

PCB LAYOUT

	Model No. 148-0701-301/310	Johnson	
	RoHS2 2011/65/EU	File: END LAUNCH JACK, SCREW-ON TYPE, 1.85mm	Rev. 001
	Drawn By: Betty Yu	148-0701-301/310	12/12/2017
	DATE: 12/12/2017	SIZE: C	DRAWING: NONE

Mouser Electronics

Authorized Distributor

Click to View Pricing, Inventory, Delivery & Lifecycle Information:

[Cinch Connectivity Solutions:](#)

[148-0701-301](#)