

BT121 BLUETOOTH SMART READY MODULE
DATA SHEET

Wednesday, 13 May 2015

Document Version: 1.2



A Silicon Labs Company

Copyright © Silicon Labs

All rights reserved.

Silicon Labs assumes no liability or responsibility for any errors, mistakes or inaccuracies in content. Silicon Labs reserves the right to change products or specifications without notice, and does not make any commitment to update the information herein.

Silicon Labs' products are not authorized for use as critical components in life support devices or systems.

BGScript™ is a trademark of Silicon Labs.

The *Bluetooth*® word mark and logos are registered trademarks owned by the *Bluetooth*® SIG, Inc. USA.

All other trademarks and trade names listed herein belong to their respective owners.

Information is subject to change without notice.

VERSION HISTORY

Date Edited	Comment
1.0	First release of document
1.1	Minor updates
1.2	Minor updates

TABLE OF CONTENTS

1	BT121 overview	6
1.1	Key Features	6
1.2	Typical applications	7
1.3	Block diagram	7
2	Design guidelines	8
2.1	PCB layout recommendations	8
2.2	Power supply recommendations	8
2.3	Software application related options	8
2.4	Firmware updating related recommendations	8
3	Pin-out description	10
3.1	Power, ground, reset, RF and boot loader pins	10
3.2	GPIO pins	11
4	Power control	12
4.1	Power supply requirements	12
4.2	Power saving functionality	12
4.3	Reset	14
4.4	Recovery mode	14
4.5	Clock signals	14
5	Interfaces	15
5.1	GPIO	15
5.2	UART	16
5.3	I ² C	16
5.4	SPI	16
5.5	ADC	16
5.6	DAC	16
5.7	Real-time clock	16
5.8	Microcontroller programming interface	16
6	Antenna	17
6.1	Effect on antenna matching of a plastic sheet placed near the antenna	18
6.2	Effect on antenna matching of a metal sheet placed under the antenna	19
6.3	Effect on antenna matching of a metal sheet placed against the end of the module	20
6.4	Measured antenna efficiency	21
6.5	Measured 2D radiation patterns	22
6.6	Measured 3D radiation patterns	24
7	Bluetooth Stack Software	25
8	Host interface	26

8.1	UART	26
9	Connection examples	27
9.1	Connecting an external host using the UART interface	27
9.2	Connecting an external device using SPI interface	28
9.3	Connecting an external device using I ² C interface	29
10	Electrical characteristics	30
10.1	Absolute maximum ratings	30
10.2	Recommended operating conditions	30
10.3	Logic signal characteristics	31
11	RF Characteristics	34
11.1	Supported frequencies and channels	34
11.2	Typical receiver sensitivity	34
11.3	Transmitter output power	34
11.4	Carrier frequency accuracy	34
12	Physical dimensions	35
13	Soldering recommendations	37
13.1	Soldering profile example	38
14	Tape and reel packaging	39
14.1	Reel material and dimensions	39
14.2	Tape material and dimensions	39
14.3	Tape and reel box dimensions	40
14.4	Module orientation in tape	40
15	Certifications	41
15.1	CE	41
15.2	FCC and IC	41
16	Ordering information	45
17	Contact Information	46

1 BT121 overview

BT121 is a Bluetooth Smart Ready module targeted for applications that require both Bluetooth Smart and Classic connectivity. It can connect to legacy devices that only support Bluetooth SPP or Apple® iAP2 profiles as well to devices that support Bluetooth Smart. BT121 integrates a high performance Bluetooth radio, a low-power ARM Cortex micro-controller and a Bluegiga Bluetooth Smart Ready stack software making it extremely easy-to-use as no RF or Bluetooth software development is needed. BT121 can be used as a modem together with a separate host MCU, but applications can also be embedded into the built-in ARM® Cortex® MCU with the Bluegiga BGScript™ scripting language.

1.1 Key Features

Bluetooth features

- Bluetooth 4.1 Smart Ready compliant
- Master and slave modes
- Up to 6 x BR/EDR connections
- Up to 7 x BLE connections
- 1 x BR/EDR + 7 x BLE connections simultaneously

Radio features

- Integrated antenna
- TX Power
 - +12 dBm with Bluetooth BR/EDR
 - +10 dBm with Bluetooth LE
- RX Sensitivity
 - -96 dBm
- 200-400 meter LoS range

Software features

- Integrated Bluetooth Smart Ready Stack
- SPP, iAP2, GATT over BR Bluetooth profiles
- Any GATT based Bluetooth Smart profile
- 1000 kbps throughput over SPP
- 150 kbps throughput over iAP2
- 100 kbps throughput over BLE
- BGAPI™ serial protocol API over UART for modem usage
- BGLIB™ host API/library which implements BGAPI serial protocol
- BGScript™ scripting language for standalone usage
- Profile Toolkit™ for creating GATT based services

Hardware interfaces

- UART host interface
- 2 x SPI, UART and 2 x I2C peripheral interfaces
- Up to 22 x GPIO with interrupts
- 4 x 12-bit ADC and 2 x 12-bit DAC*
- Internal temperature sensor*
- Internal battery voltage measurement option*
- Clock generator*
- RTC with calendar*

Microcontroller

- ARM Cortex M0
- 48 Mhz
- 16kB RAM
- 128kB flash

Electrical characteristics

- Supply voltage: 2.2V to 3.6V
- Supply voltage: 2.4V to 3.6V when using ADC

Environmental and regulatory

- Temperature range: -40C to +85C
- Bluetooth, CE, FCC and IC, Japan and South-Korea qualified*

Dimensions:

- W x L x H: 11.0 mm x 13.9 mm x 2.2 mm

*) Feature not implemented on engineering samples and engineering samples are not qualified

1.2 Typical applications

BT121 can be used in a wide variety of applications such as health and fitness, PoS (point-of-sales), M2M connectivity, automotive aftermarket, industrial and home automation gateways and others.

1.3 Block diagram

The block diagram for Bluegiga *Bluetooth* Smart Ready module BT121 is shown in below.

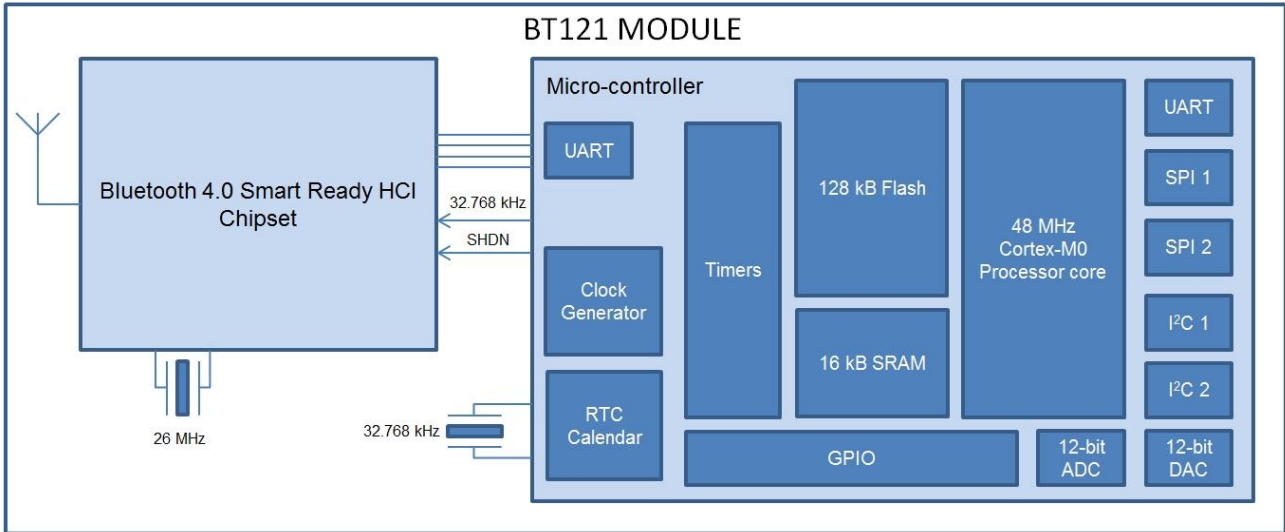

Figure 1 BT121 Bluetooth Smart Ready module block diagram

2 Design guidelines

Certain hardware related design guidelines should always be followed when developing applications based on the BT121 module.

2.1 PCB layout recommendations

- All ground pads should be connected to a ground plane.
- The antenna layout should follow the example shown in [Figure 2](#) below and avoid the designs shown as crossed over.
- BT121 requires minimal free space around the module and only the white area marked in the PCB picture series presented in [Figure 2](#) below needs to be free of copper and components.

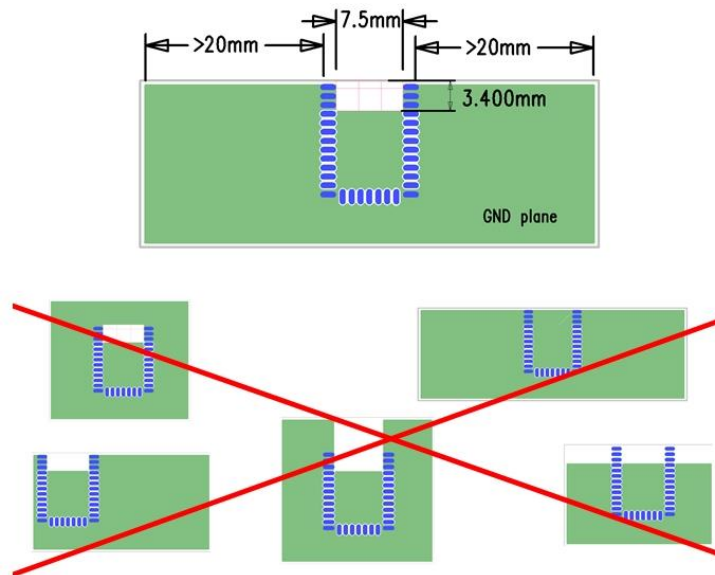

Figure 2 PCB layout recommendations for BT121 application boards

2.2 Power supply recommendations

The regulator used must be capable of supplying a peak current of 150 mA and the regulator must be of a type stable with ceramic capacitors.

2.3 Software application related options

BT121 can be used either as a stand-alone solution by using the Bluegiga BGScript™ scripting language or alternatively if the application software size or other factors require together with an external host processor by using Bluegiga BGAPI™ commands. The decision on which approach to use is most often dictated by the limits set by the internal memory of the BT121 module.

2.4 Firmware updating related recommendations

To enable firmware updating an external UART interface connection as shown in [Figure 3](#) on the next page is mandatory. BT121 firmware can be updated through the UART interface by holding the host MCU in reset state which typically will free the UART lines to be used by the update interface.

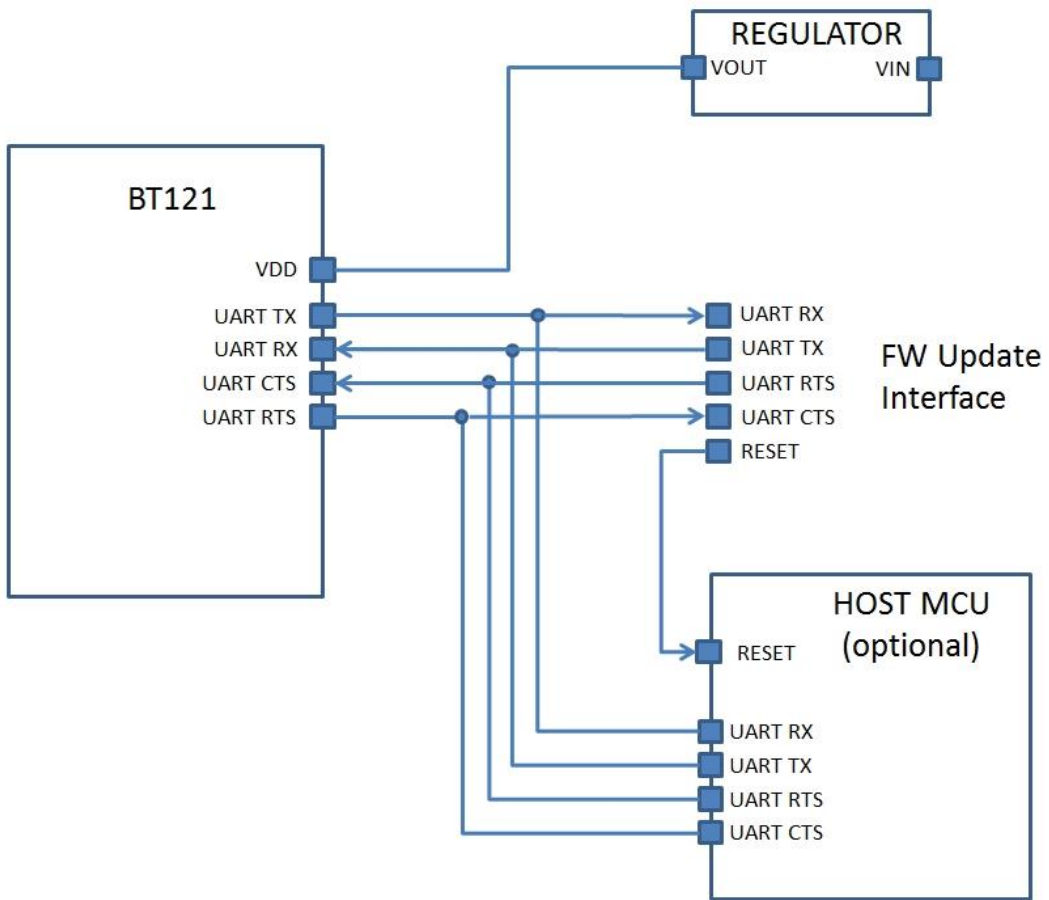

Figure 3 BT121 firmware update via UART connection example

3 Pin-out description

This section contains a description of the BT121 pin-out. Each pin may have one or more functions which are all listed in tables. The pin-out is shown in [Figure 4](#) below.

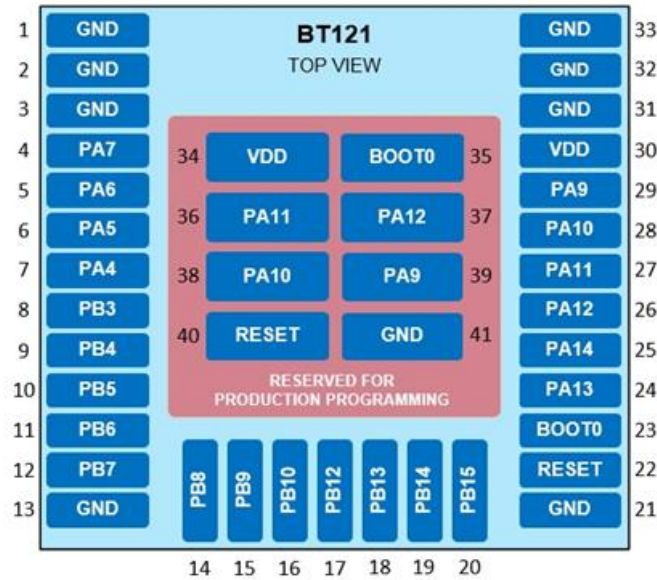

Figure 4 BT121 pin-out (top view)

3.1 Power, ground, reset, RF and boot loader pins

Power supply, ground, reset signal, RF antenna input/output and boot loader related pins are listed in [Table 1](#) below.

Pin / Pad	Function	Description
30,34	VDD	Module power supply input pins.
1, 2, 3, 13, 21, 31, 32, 33, 41	GND	Ground pin. These are all connected together internally but they should all be individually connected directly to a solid ground plane with vias in close proximity to the pins. This requirement concerns especially the antenna connections.
22,40	RESET	Module reset signal pins. Pulling RESET low will reset the internal processor of the module. These connections have an internal pull-up and can be left floating if not needed.
23,35	BOOT0	Boot mode pin of the microcontroller internal boot loader. This connection has an internal pull-down and should be left floating or pulled low in normal operation. If the Bluegiga DFU is overwritten or disabled, pulling BOOT0 high at reset will allow DFU to be rewritten through the UART (serial port interface).

Table 1 Power, ground, reset, RF and boot loader pins

3.2 GPIO pins

General purpose I/O pins and their functions are listed below.

PERIPHERAL FUNCTION	GPIO NAME																						
	PA7	PA6	PA5	PA4	PB3	PB4	PB5	PB6	PB7	PB8	PB9	PB10	PB12	PB13	PB14	PB15	PA13	PA14	RTS PA12	CTS PA11	RX PA10	TX PA9	
PIN NUMBER	4	5	6	7	8	9	10	11	12	14	15	16	17	18	19	20	24	25	26 37	27 36	28 38	29 39	
DEFAULT FUNCTION **	dc	dc	dc	dc	dc	dc	dc	dc	dc	dc	dc	dc	dc	dc	dc	dc	dc	dc	dc	RTS	CTS	RX	TX
5V TOLERANT	N	N	N	N	Y	Y	Y	Y	Y	Y	Y	Y	Y	Y	Y	Y	Y	Y	Y	Y	Y	Y	Y
UART ***																			RTS	CTS	RX	TX	
SPI 1	Alt.1	MOSI	MISO	SCK	NSS*																		
	Alt.2				NSS*	SCK	MISO	MOSI															
SPI 2	Alt.1										NSS*	SCK			MISO	MOSI							
	Alt.2												NSS*	SCK	MISO	MOSI							
I ² C 1	Alt.1							SCL	SDA														
	Alt.2									SCL	SDA												
I ² C 2	Alt.1																						
	Alt.2													SCL	SDA								
DAC output				AO2	AO1																		
ADC input	AIN7	AIN6	AIN5	AIN4																			
Interrupt channel	7	6	5	4	3	4	5	6	7	8	9	10	12	13	14	15	13	14	12	11	10	9	

Table 2 General purpose I/O pins and their functions

* NSS signal is optional, see SPI description (Section 5.4)

** Default pin functions on production firmware / dc = disconnected, no need to pull up or down

*** UART can be used as a BGAPI™ host interface and DFU firmware updates

If the pins are set as GPIO rather than UART signals the DFU cannot work, see UART (Section 5.2) and recovery mode (Section 4.4)

GPIO pins 36, 37, 38 and 39

Reserved for production testing

Must be left unconnected



I2C 2 cannot be used in Alt. 2 configuration

4 Power control

4.1 Power supply requirements

BT121 is powered by a single power supply input (VDD). Nominal input voltage is 3.3 VDC and input voltage range 2.2 V to 3.6 V. If the module's internal ADC and/or DAC functions are used minimum allowed power supply voltage is 2.4V.

The VDD supply should be capable of supplying a peak current of at least 150 mA even though the average current consumption of BT121 will be much less than that. External high frequency bypass capacitors are not needed because the module contains the necessary power supply filtering capacitors.

Careful design of the layout and proper component selection are necessary to prevent switching noise from appearing on the supply line. Such disturbances can be caused by on-board charge pump converters (e.g. RS232 level shifters). Charge pump based converters tend to have strong switching spikes which are difficult to filter out and may degrade RF performance. A ferrite chip can be added in series with the supply line close to the module supply pin to reduce RF interference through the supply line.

There is a total of about 1.5 μF of ceramic capacitors on the VDD line inside the module. When using low drop linear regulators to generate a regulated supply voltage for the VDD line, the stability of the regulator with the low ESR provided by these capacitors should be checked. Many linear regulators and some switched mode ones too are not stable when used with ceramic output capacitors. The regulator datasheets usually have recommendations for output capacitor ESR range or they contain a stability curve to help select components properly. A regulator designated as "stable with ceramic capacitors" is recommended.

4.2 Power saving functionality

BT121 contains two configurable power saving modes. The internal RTC (Real Time Clock) is usually kept always running to avoid the long wake-up time associated with the internal 32 kHz crystal oscillator. The RTC is always available to wake up the module.

4.2.1 Power mode 1

Power mode 1 is a shallow sleep state with all clocks and peripherals running but with the processor core stopped. It is used automatically and has no impact on module performance and does not require special considerations in user applications. See [Table 3](#) on next page.

4.2.2 Power mode 2

Power mode 2 is a deep sleep state, in which most peripheral devices and system clocks are powered down. The UART interfaces cannot operate without clocks, and instant communications with the host are not possible. A separate wake-up command on the host UART or a PIO interrupt can be used to wake up the module, or an RTC event. The radio can also cause a wake-up event. There is a short wake-up delay due to the time required for the internal clocks to stabilize and because of this the module processor is not instantly ready to receive data.

The radio part of the BT121 can be physically shut down with software to reduce module sleep consumption to the minimum. This can be useful when the application only needs to connect to a remote system periodically. Powering the radio up again will require a re-initialization of the radio, which will cause a relatively long delay. See [Table 3](#) on next page.

Power mode	CPU clocks	CPU core	Radio	Wakeup delay	UART	Current consumption *
Active	ON	Running	On	-	Active	10 - 20 mA
Power mode 1	ON	Stopped	On	< 7 μ s	Active	4 - 10 mA
Power mode 2	OFF	Powered off	On	< 70 μ s	Off	50 - 100 μ A
Power mode 2 RF OFF	OFF	Powered off	Off	< 500 ms Until radio is on again	Off	5 - 10 μ A

Table 3 Power modes with corresponding wakeup delays and current consumption

* Current consumption with radio inactive

The logic flow of the power saving modes in relation to each other is shown in [Figure 5](#) below. It is to be noted that the processor will not lose RAM contents regardless of the power mode used.

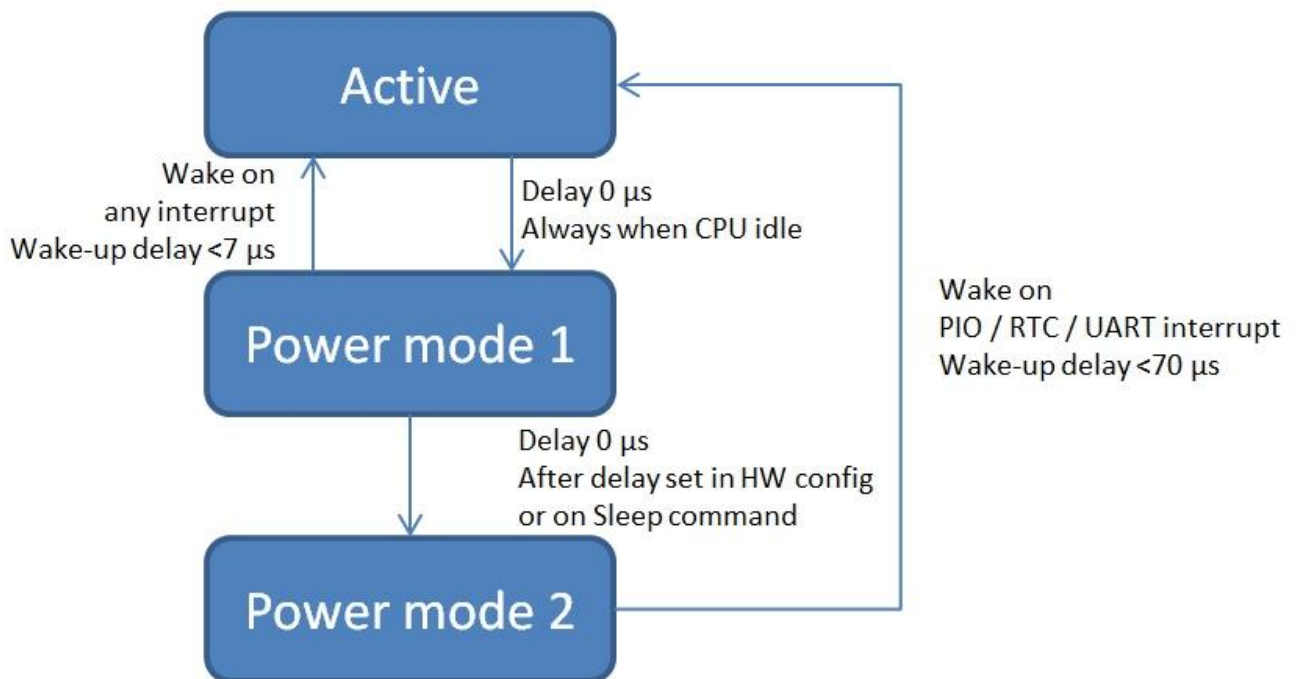

Figure 5 Power modes in relation to each other and to active mode

4.3 Reset

BT121 can be reset by several methods: by pulling the RESET pin low, by the internal system power-up reset functionality or by the internal watchdog timer. The RESET pin is internally connected to a pull-up resistor with a resistance of approximately 40 kohm. The RESET pin should be connected to a push-button, header or test point to enable the use of the system recovery mode.

4.4 Recovery mode

Pulling the BOOT0 pin high at reset sets the BT121 module's internal microcontroller into a recovery mode, which allows the Bluegiga DFU to be rewritten to the module using the DumoGUI software. The BOOT0 pin should be connected to a header or test point to enable DFU recovery. The pin is internally connected to a 10 kohm pull-down resistor.

4.5 Clock signals

BT121 generates all the required clock signals internally. The clocks used by the internal microcontroller and external peripherals are synchronized to an internal 32.768 kHz crystal connected to the internal RTC. The micro power RTC is always kept running when the module is supplied with power. It will take approximately two seconds for the RTC oscillator to stabilize after power is connected. To avoid this delay it is recommended that the power supply feed to the BT121 is not switched off but instead the module can be set into the lowest power mode providing the smallest current consumption.

5 Interfaces

5.1 GPIO

BT121 contains a number of pins which can be configured to operate as general purpose digital I/O's, analog inputs or outputs or to be used in combination with various built-in functions. The module contains I2C, SPI, UART, touch pad sensing and various timer functions. Most of the pins are 5V tolerant. All GPIO pins can drive currents of up to +/- 8 mA (up to 20mA with relaxed voltage specifications).

5.1.1 GPIO interrupts

Any GPIO signal can be assigned an interrupt function. However, the module microcontroller has a limited number of interrupt channels available for GPIO's. The microcontroller has two separate GPIO ports, with the external signals divided between the two. An interrupt can be assigned to a specific port signal number from either port, but not for the same number on both ports simultaneously. The principle of GPIO interrupt multiplexing on the Bluegiga *Bluetooth* Smart Ready module BT121 is shown in [Figure 6](#) below.

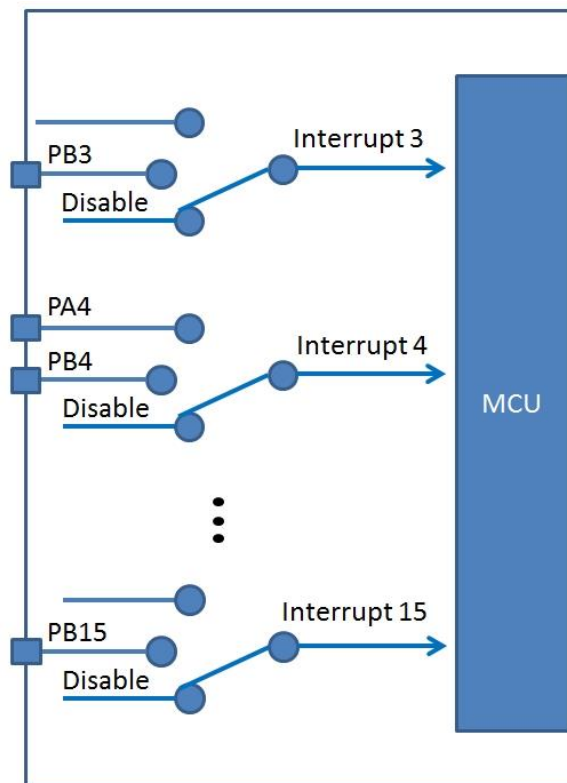

Figure 6 GPIO interrupt multiplexing scheme

5.2 UART

There is one UART port available on the BT121. By default it is used for BGAPI™ host interface but with BGScript™ it can be used as an application UART. The UART supports all standard baud rates up to 4 Mbps. RTS/CTS handshake scheme is supported and recommended for every application for reliable data transfer.

5.3 I²C

BT121 has up to two I²C ports available. Both support standard mode up to 100 kbps, fast modes up to 400 kbps and Fast Mode Plus with improved drive capability and clock stretching up to 1 Mbps.

5.4 SPI

BT121 has up to two SPI ports available. Both can be configured for frame sizes from 4 to 16 bits and clock frequencies up to 18 MHz. Both ports provide internal CRC calculation. An optional slave select signal (NSS) is provided for hardware assisted data strobing in applications requiring high bus throughputs.

5.5 ADC

BT121 contains a 4-channel 12-bit ADC with multiple external input sources as well as an internal battery measurement and temperature measurement possibility. ADC input voltage range is 0 to VDD.

5.5.1 Accessory functions of the ADC

In addition to the external ADC inputs an internal temperature sensor or internal supply voltage divider can be selected as the input to ADC.



Power supply range when using internal ADC functions is 2.4 to 3.6 VDC.

5.6 DAC

BT121 contains a 2-channel 12-bit DAC, with two independent outputs. DAC output voltage range is 0 to VDD.



Power supply range when using internal DAC functions is 2.4 to 3.6 VDC.

5.7 Real-time clock

BT121 contains a real-time clock (RTC) with full calendar support and sub-second resolution. The RTC can be used for periodic or specifically programmed wakeups. The RTC is clocked by an internal crystal oscillator which is always on as long as power is supplied to the module.

5.8 Microcontroller programming interface

The preferred method of programming the BT121 is by using the Bluegiga DFU through the UART host interface. A problem may occur if the DFU is disabled by disabling the UART or if the DFU is overwritten accidentally. Then the DFU would need to be re-uploaded.

The two methods of firmware upload are through the SWDIO/SWCLK interface (PA13 and PA14) using an ARM serial debug adapter, or by forcing the BOOT0 signal high and by resetting the module to make it boot into a recovery mode. Then the BGTool software can be used to recover the DFU through the UART interface.

6 Antenna

The internal chip antenna on the BT121 uses the application board ground plane as part of the antenna, and requires at least 20 mm of ground plane on both sides of the module to radiate with optimal efficiency. BT121 must be placed on the application board edge, preferably roughly in the middle of the board edge. The ground plane can be internal to the application PCB, allowing components to be placed on both sides of the module and on both sides of the application board. The module ground pads in the antenna end should be connected to the main ground plane layer with vias in immediate proximity of the pins. Thermal reliefs on the ground pins have a negligible effect on antenna performance. Typical antenna matching curves are shown in [Figure 7](#) below.

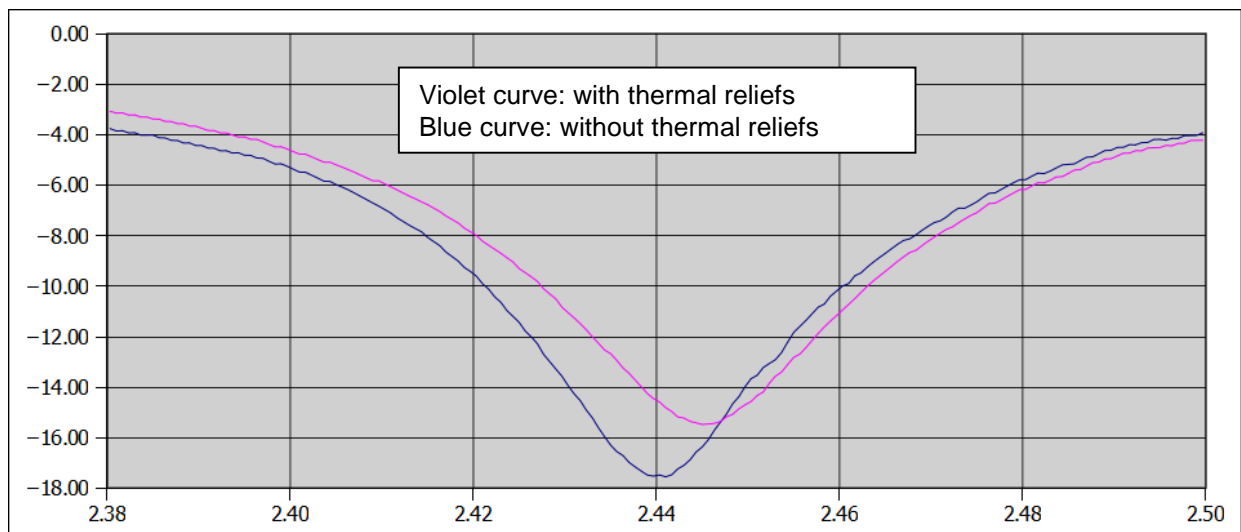

Figure 7 Typical antenna matching

The antenna used on the BT121 is quite robust with regard to adverse effects of close-by metallic materials. The PCB thickness will not affect the antenna operation significantly. The application board can be installed with the PCB bottom side and the antenna edge directly against a plastic casing without adverse effects. On the module top side, there should be at least 3 mm of clearance to the nearest object.

The antenna requires a 7.5 x 3.4 mm sized copper clearance in all layers, with no components or traces on the opposite side of the PCB from the antenna. Sufficient metal clearance is mandatory because the antenna will not function at all without a sufficient opening in the ground plane.

Any metal in close proximity of the antenna will prevent the antenna from radiating freely. It is recommended not to place any metal or other conductive objects closer than 10 mm to the antenna except in the directions of the application board ground planes.

A board cutout is not required for the antenna. In fact, a cutout would cause the antenna to be detuned which in turn will degrade range significantly. The module is also not to be placed in a cut-out recess on the board edge or in the middle of the board which has a central cutout.

On the following pages are examples on how plastic or metal sheets in several different orientations and distances to the antenna affect antenna matching.

6.1 Effect on antenna matching of a plastic sheet placed near the antenna

As an example on how a plastic sheet placed in the vicinity of the module and/or antenna effect the antenna matching we can examine [Figure 8](#) below.

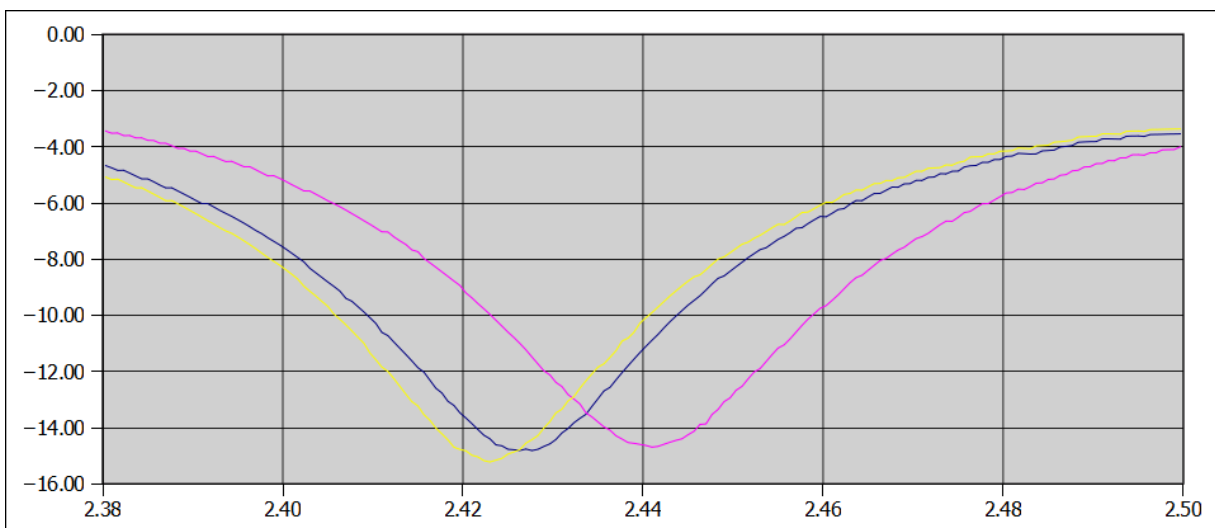
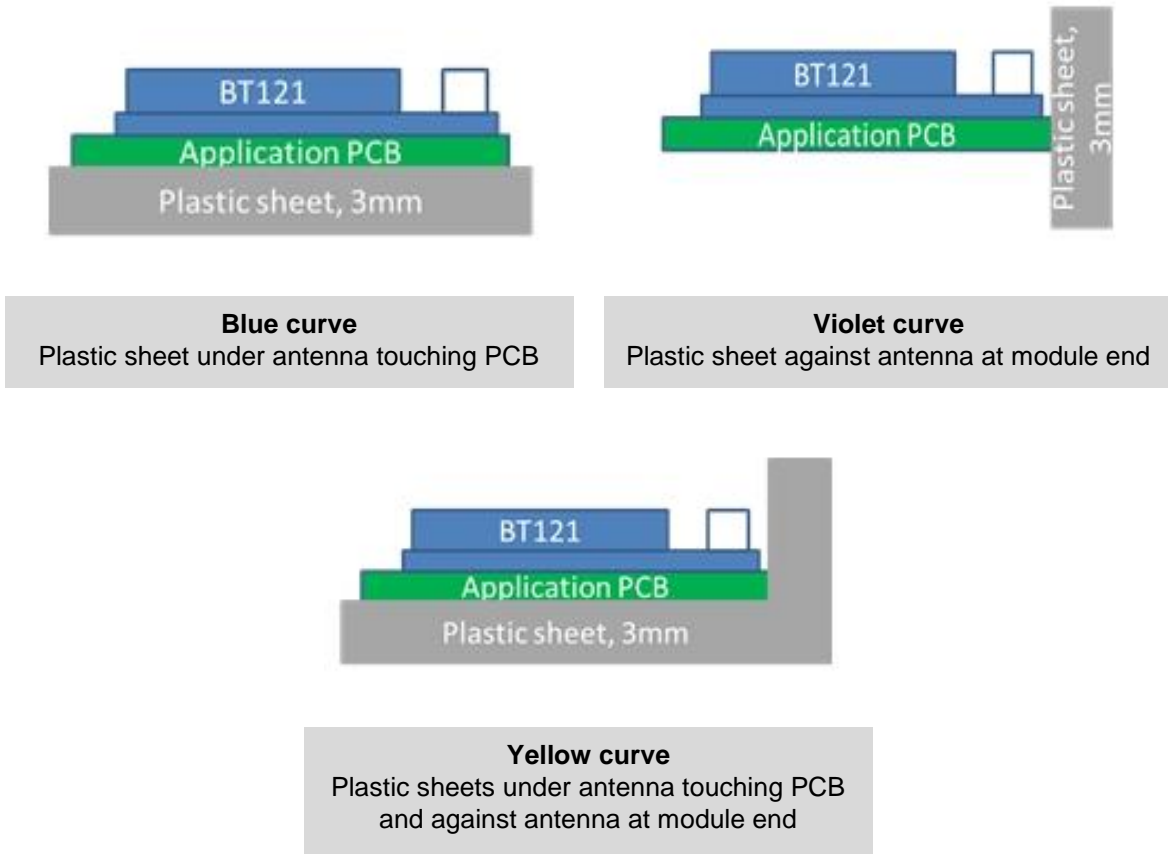

Figure 8 Proximity effect of a 3 mm plastic sheet on antenna matching with different placements

6.2 Effect on antenna matching of a metal sheet placed under the antenna

As an example on how a metal sheet placed in the vicinity of the module and/or antenna effect the antenna matching we can examine [Figure 9](#) below.

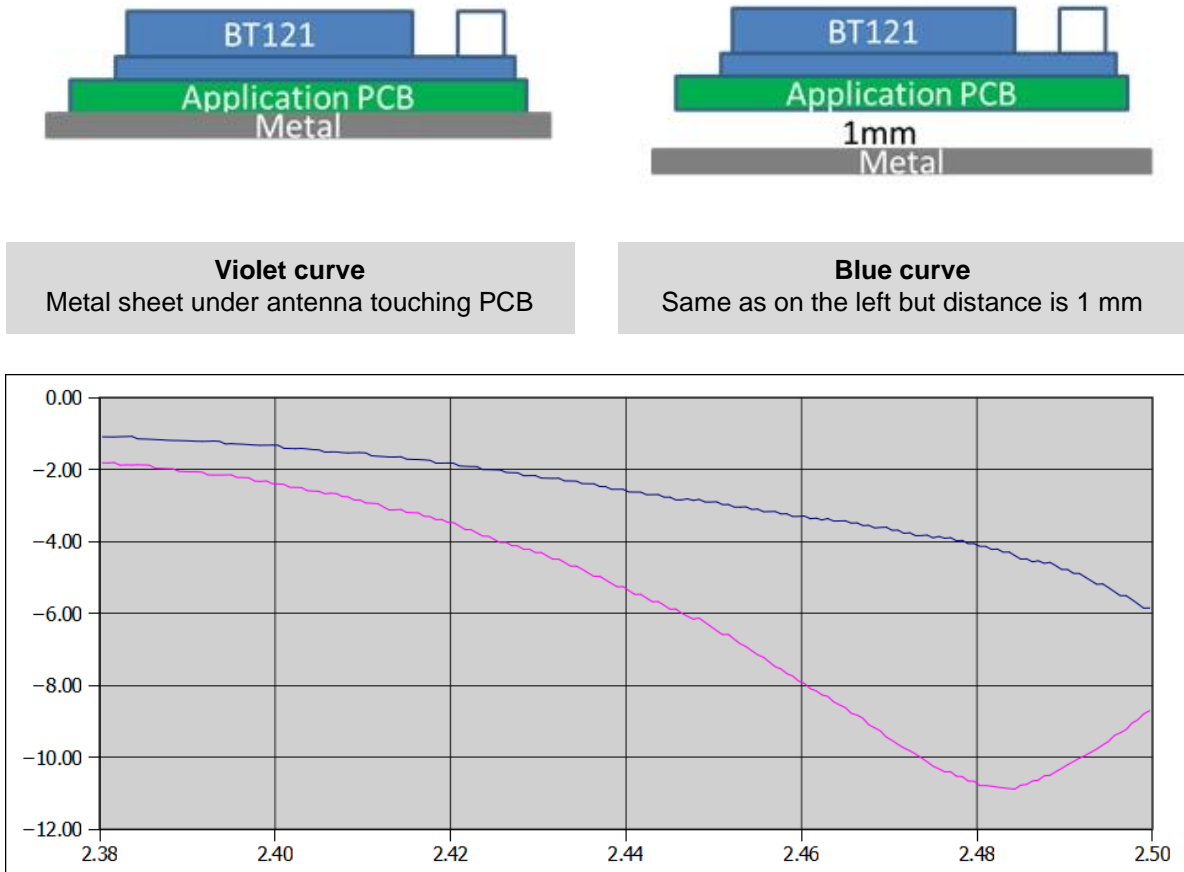

Figure 9 Effect of a metal sheet placed under the antenna on antenna matching

6.3 Effect on antenna matching of a metal sheet placed against the end of the module

As an example on how a metal sheet placed in the vicinity of the module and/or antenna effect the antenna matching we can examine [Figure 10](#) below.

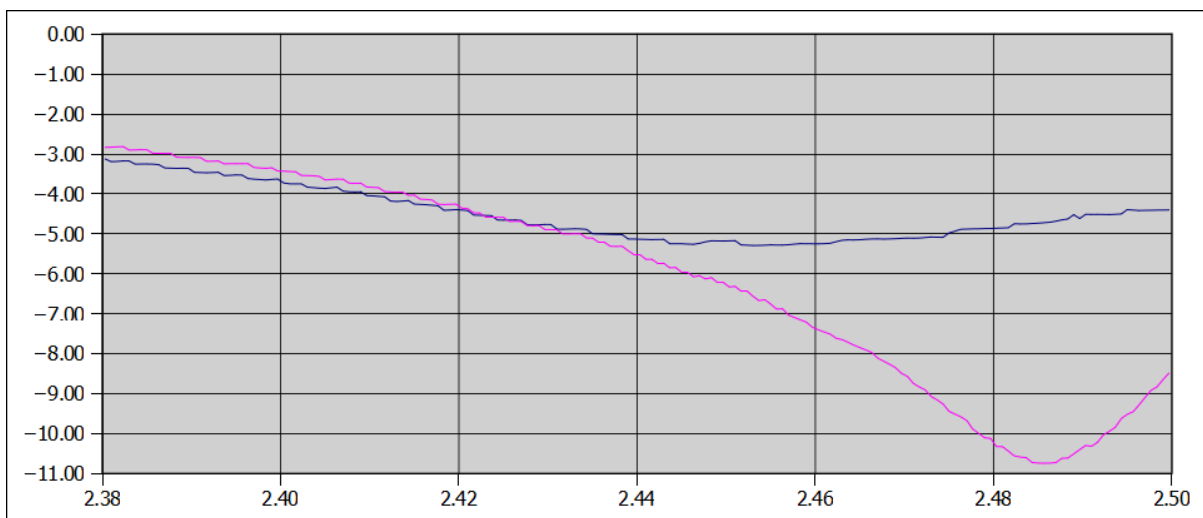
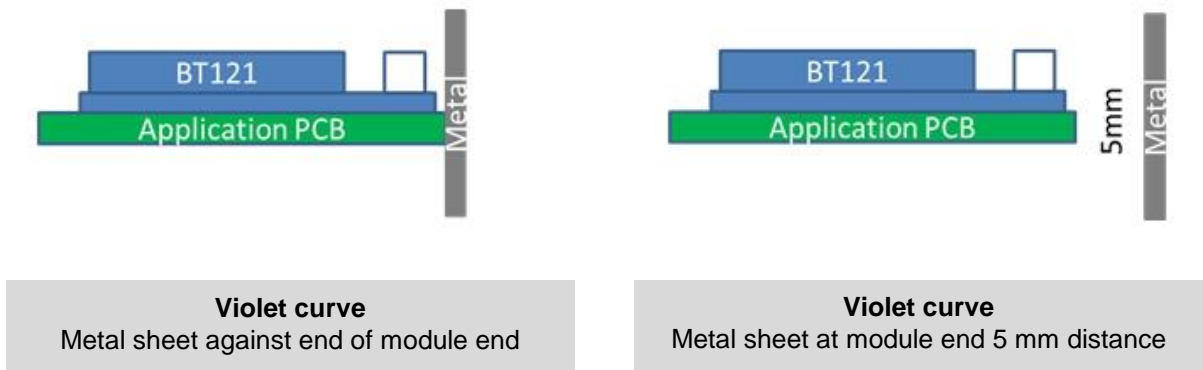

Figure 10 Effect of a metal sheet placed under the antenna on antenna matching

6.4 Measured antenna efficiency

The measured antenna efficiency as a function of frequency is shown in [Figure 11](#) below.

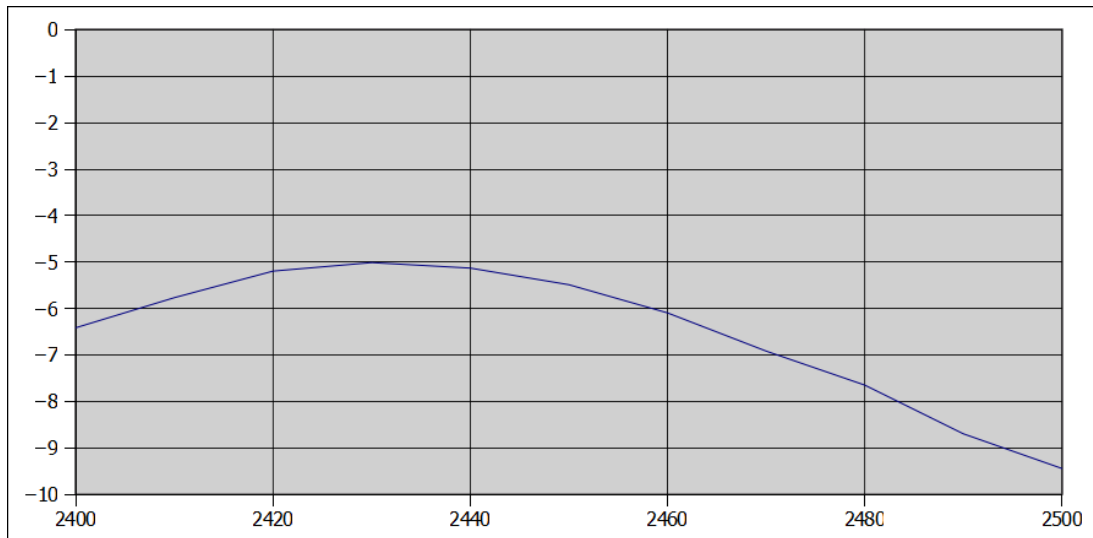

Figure 11 Antenna efficiency related to frequency

6.5 Measured 2D radiation patterns

Typical radiation patterns of the BT121 module shown as 2D plots are shown below in [Figure 12](#) (view from module side), [Figure 13](#) (view from antenna end) and on the following page in [Figure 14](#) (view from above module).

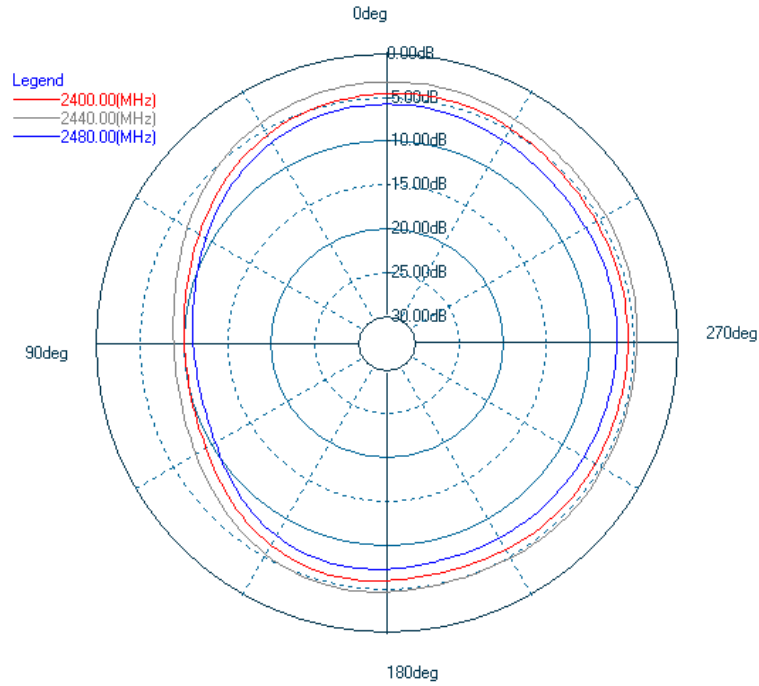

Figure 12 Typical 2D radiation pattern for BT121 with view from module side

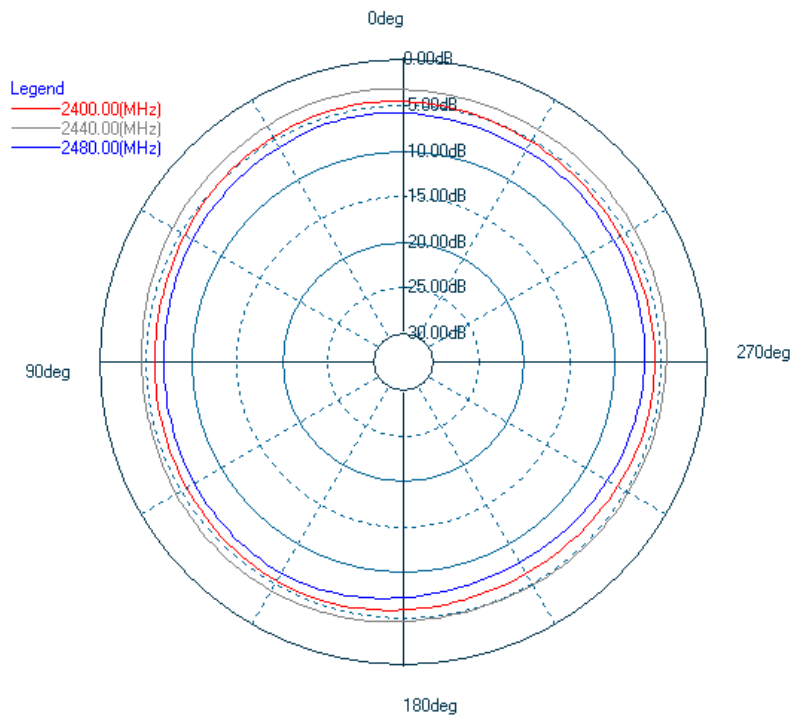

Figure 13 Typical 2D radiation pattern for BT121 with view from antenna end side

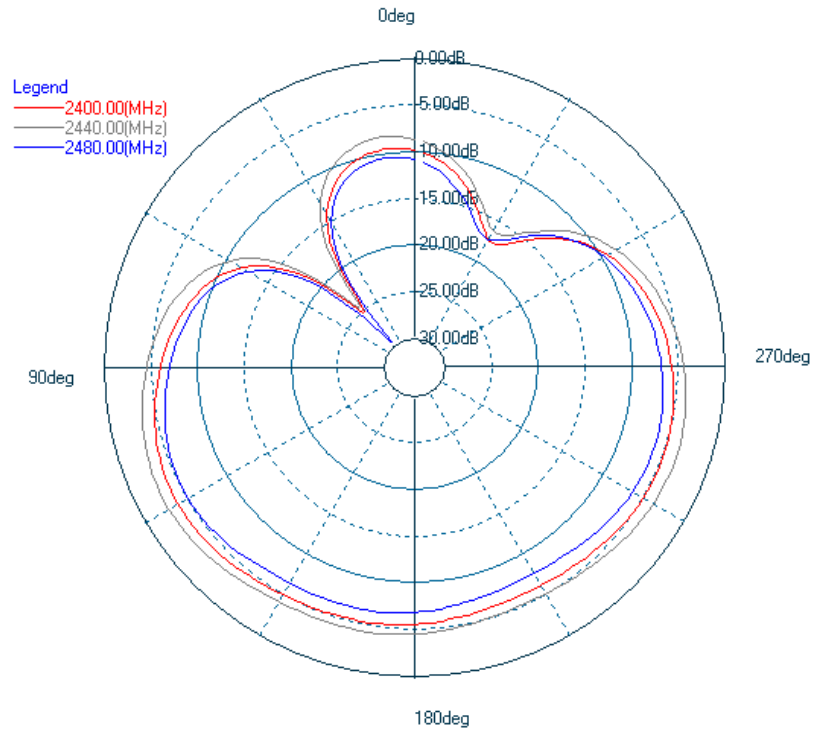

Figure 14 Typical 2D radiation pattern for BT121 with view from above module

6.6 Measured 3D radiation patterns

Typical radiation patterns of the BT121 module shown as 3D plots are shown below. *Figure 15* represents a radiation pattern from module end side opposite to antenna and *Figure 16* from above the module.

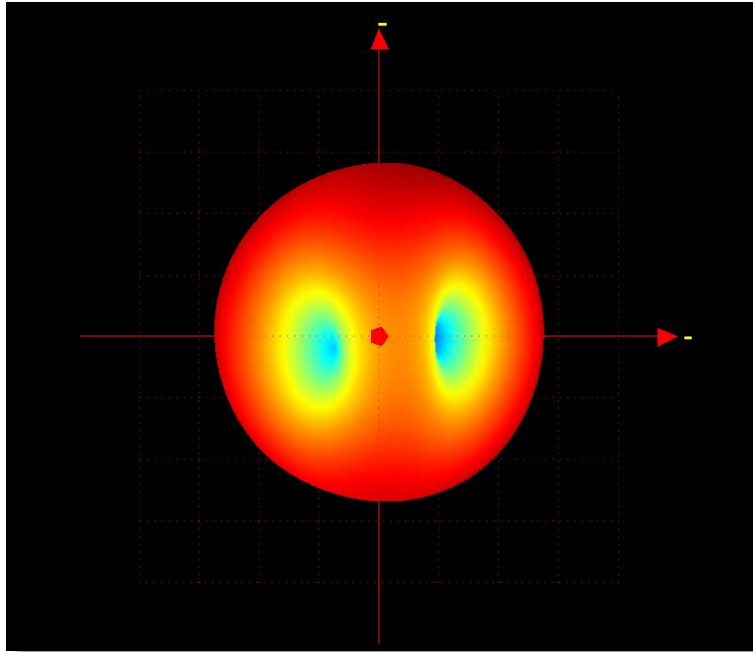

Figure 15 Typical 3D radiation pattern for BT121 with view from module end opposite to antenna

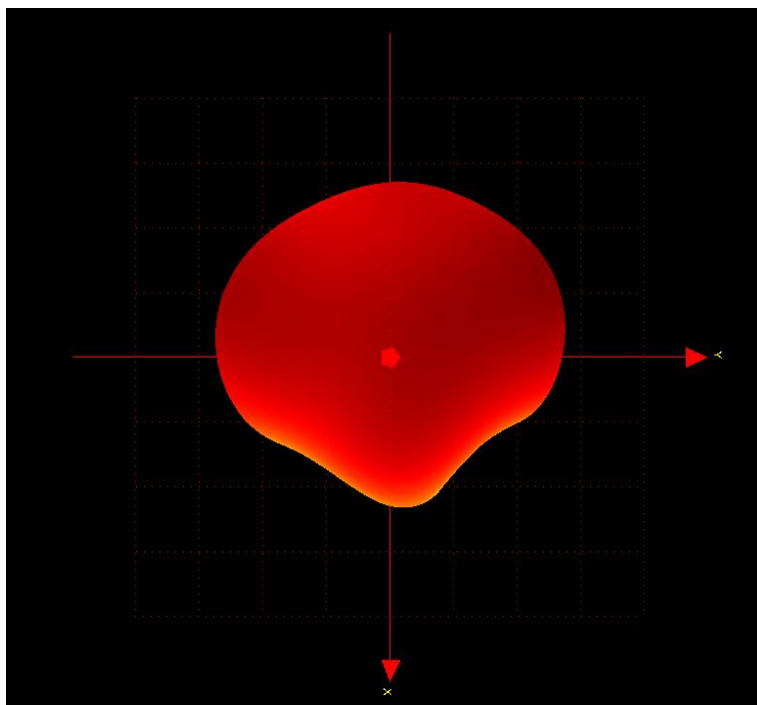

Figure 16 Typical 3D radiation pattern for BT121 with view from above the module

7 Bluetooth Stack Software

Bluegiga's *Bluetooth Smart Ready Software* is a complete *Bluetooth Smart Ready* software stack for BT121 *Bluetooth Smart Ready* module. The software implements a full *Bluetooth* BR/EDR and LE compatible *Bluetooth Stack* and L2CAP, RFCOMM, SMP and ATT protocols as well as *Bluetooth SPP*, Apple iAP2, GATT over BT profiles and any GATT based *Bluetooth Smart* profile.

The *Bluetooth Smart Ready Software* also is supported by a complete SDK for developing *Bluetooth Smart Ready* applications using either an external host or BGAPI™ serial protocol over UART or fully standalone applications based on a simple scripting language called BGScript™.

Several profiles and software project examples are offered as part of the *Bluetooth Smart Ready SDK* to help expedite the development of *Bluetooth Smart Ready* compatible end-user products.

The main parts of the Bluegiga *Bluetooth Smart Ready* software stack are shown below.

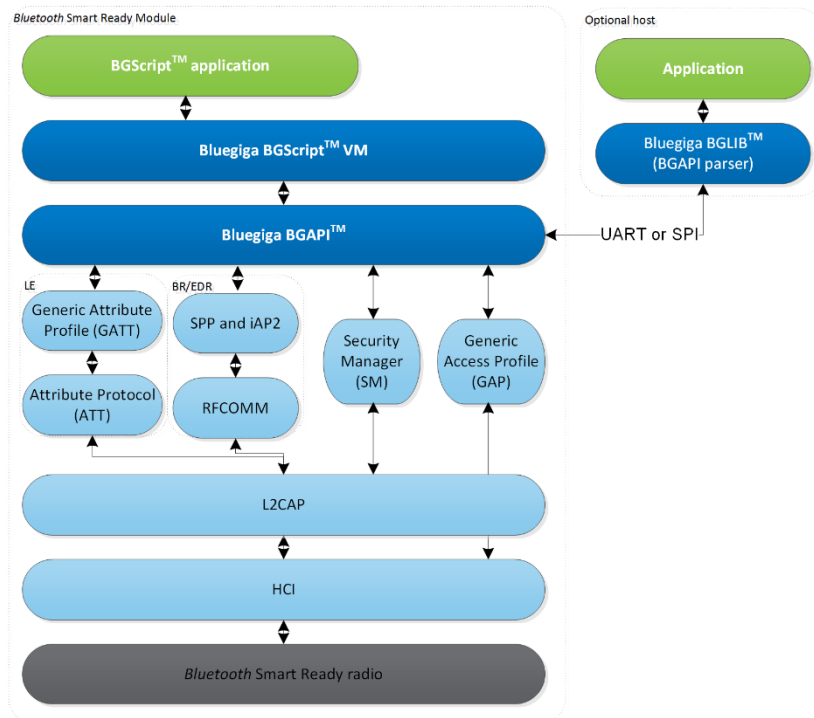

Figure 17 Bluegiga Bluetooth Smart Ready software stack



To learn more about the Bluetooth Smart Ready software stack, the SDK and the APIs please read ***Bluetooth Smart Ready Software Getting Started Guide***.

8 Host interface

8.1 UART

For applications where an external host such as MCU is used BT121 can be controlled over the UART interface using the BGAPI™ serial protocol.

For reliable communications can data transfer the hardware flow control RTS/CTS signals must be used in the UART interface.

It is also recommended that the accuracy of the clock of the controlling host should be 1% or better for the UART signaling to work reliably with speeds exceeding 115200 kbps (maximum baud rate is 4 Mbps).

Default UART settings are listed below:

Parameter	Default setting
UART baud rate	115200
RTS/CTS flow control	Enabled
Data bits	8
Parity	None
Stop bits	1

Table 4 BT121 UART interface default settings

9 Connection examples

The following sections show how to connect a Bluegiga *Bluetooth* Smart Ready module with various external devices using the UART, SPI and I²C interface.

9.1 Connecting an external host using the UART interface

The connection to an external host is done using the UART interface of the module. This interface is also used for module reprogramming using the DFU method and thus an optional connector should be provided on the application PCB to allow reprogramming if needed. A typical solution then is to hold the host in reset state which will keep the UART pins of the host floating, allowing the interface to be used for programming the module by using e.g. a PC and suitable software. See [Figure 18](#).

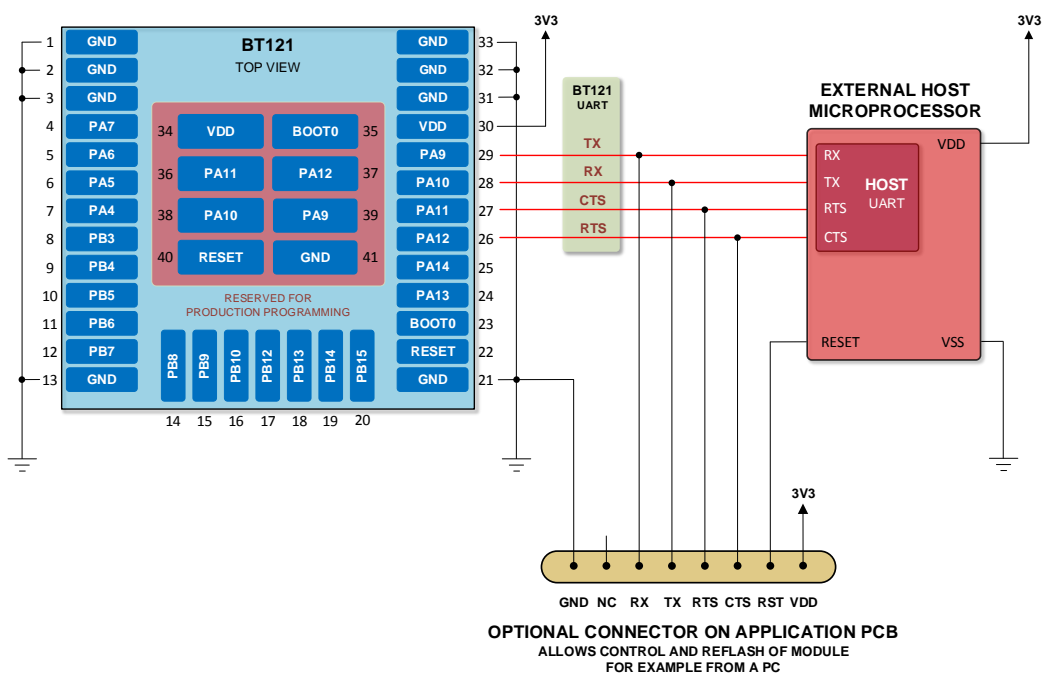

Figure 18 Connecting an external host with BT121 using UART

9.2 Connecting an external device using SPI interface

Bluegiga *Bluetooth* Smart Ready module BT121 contains two physical SPI peripherals (SPI 1 and SPI2) each with alternative configurations (Alt 1 and Alt 2). All of the four optional configurations can be used to connect different types of peripheral devices to the module. Pin configurations for the four SPI interface options are listed in [Table 2](#). An example of this type of interfacing is shown in [Figure 19](#) below. In the example below a generic EEPROM memory peripheral chip is connected to the BT121 using the **SPI 1 Alt 2** option.

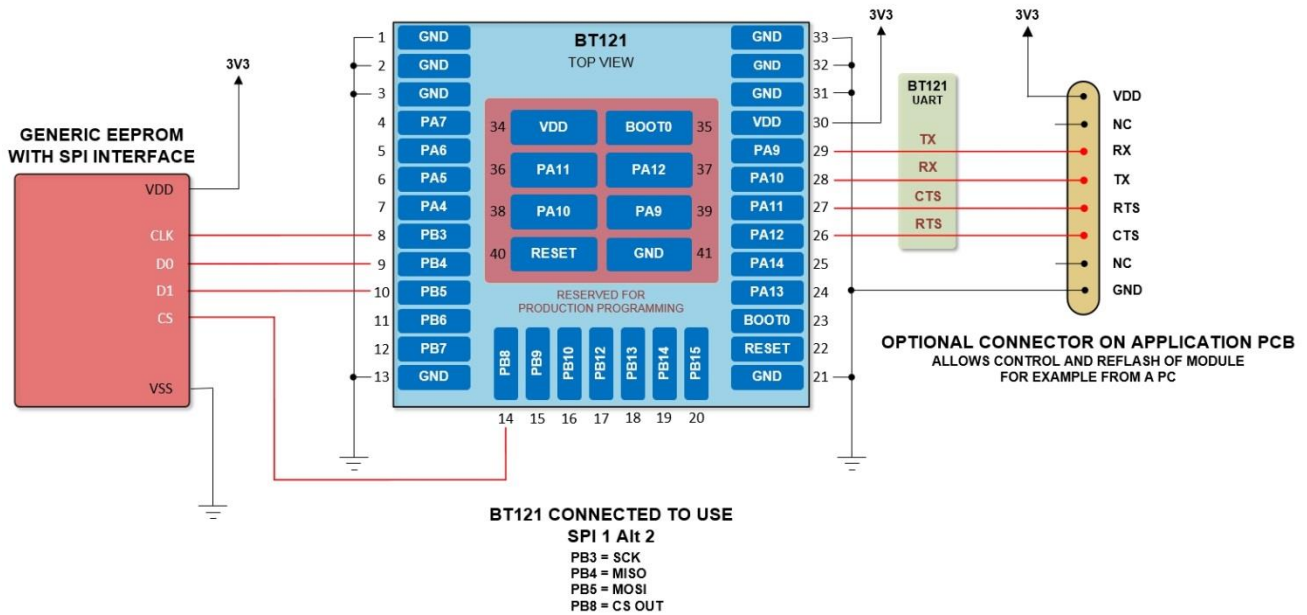

Figure 19 Connecting an external device with BT121 using SPI interface

9.3 Connecting an external device using I²C interface

Bluegiga *Bluetooth* Smart Ready module BT121 contains two physical I²C peripherals (I²C 1 and I²C 2). I²C 1 has two alternatives (Alt 1 and Alt 2) and I²C 2 one alternative (Alt 2). All of the three optional configurations can be used to connect different types of peripheral devices with the module. Pin configurations for the three I²C interface options are listed in *Table 2*. An example of this type of interfacing is shown in *Figure 20* below. Note the pull-up resistors on the SDA and SCK lines. The example shows the address/chip select lines of the generic peripherals hardwired to VDD but in practice all or some of them would be wired to GPIO pins of the BT121 configured to work as chip select or address lines controlled by the application hardware. In the example below a generic sensor chip is connected to the BT121 using the **I²C 1 Alt 1** option.

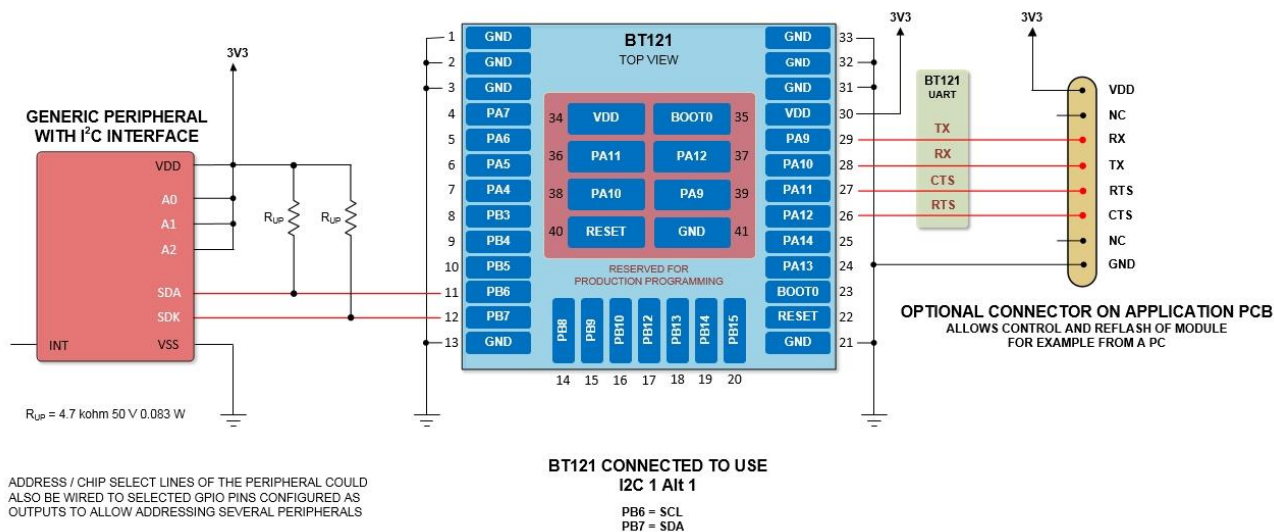

Figure 20 Connecting to an I2C peripheral

10 Electrical characteristics

10.1 Absolute maximum ratings

Parameter	Min	Max	Unit
Storage temperature	-40	85	°C
VDD	-0.3	3.6	V
5V tolerant GPIO voltages	-0.3	5.5	V
Other terminal voltages	-0.3	VDD+0.3	V
Output current sourced or sunk by any GPIO pad		25	mA
Current on all GPIO pads combined		120	mA

Table 5 Absolute maximum ratings

10.2 Recommended operating conditions

Rating	Min	Max	Unit
Operating temperature range	-40	85	°C
VDD	2.2	3.6	V
VDD (when operating ADC or DAC)	2.4	3.6	V

Table 6 Recommend operating conditions

10.3 Logic signal characteristics

10.3.1 Digital I/O

Digital I/O pins	Min	Typ	Max	Unit
Input voltage levels				
V _{IL} input logic level low 1.7V ≤ VDD ≤ 3.6V	-0.3	-	0.3VDD	V
V _{IH} input logic level high 1.7V ≤ VDD ≤ 3.6V	0.7 VDD	-	VDD + 0.3	V
Output voltage levels				
V _{OL} output logic level low, Vdd = 3.6 V, I _{ol} = 7 mA	-	-	0.4	V
V _{OH} output logic level high Vdd = 3.6 V, I _{oh} = -12 mA	VDD - 0.4	-	VDD	V

Table 7 Digital I/O pin electrical characteristics

10.3.2 Reset

Power-on Reset	Min	Typ	Max	Unit
Power on reset threshold (rising edge)	1.84	1.92	2.00	V
Power on reset threshold (falling edge)	1.80	1.88	1.96	V
RESET signal pulse width (pulled low)	500	-	-	ns

Table 8 Reset pin characteristics

10.3.3 ADC

Power-on Reset	Min	Typ	Max	Unit
ADC input impedance	-	-	50	kohm
ADC input voltage range	0	-	VDD	V
ADC differential nonlinearity error	-	0.7	1.3	LSB
ADC integral nonlinearity error	-	0.8	1.7	LSB
ADC offset error	-	1	2.8	LSB
ADC gain error	-	0.5	3	LSB

Table 9 ADC pin characteristics

10.3.4 DAC

Power-on Reset	Min	Typ	Max	Unit
DAC output load impedence	5	-	-	kohm
DAC output voltage range	0.2	-	VDD - 0.2	V
DAC differential nonlinearity	-	-	2	LSB
DAC integral nonlinearity	-	-	4	LSB
DAC offset error	-	-	12	LSB
DAC gain error	-	-	0.5	%

Table 10 DAC pin characteristics

10.3.5 Power consumption

Operation state	Current	Unit	Description
CPU active - RF idle	14	mA	CPU consumption RF sleep current
Power state 1 - RF idle	TBD	mA	CPU consumption RF sleep current
Power state 2 - RF idle	TBD	μA	CPU consumption RF sleep current
Power state 2 - RF off	TBD	μA	CPU leakage current only RF fully powered off
Reset state	12.3	mA	Reset-signal held low
Continuous transmission - BDR	92	mA	CPU consumption RF fully on
Continuous transmission - EDR	85	mA	CPU consumption RF fully on

Table 11 Power consumption of different operating schemes

11 RF Characteristics

11.1 Supported frequencies and channels

Parameter	Min	Max	Unit
Frequency	2402	2480	MHz
Channels	0	78	CH #

Table 12 Supported frequencies and channels

11.2 Typical receiver sensitivity

Packet type	-40 to 85°C	Unit
DH1	-95	dBm
2DH1	-96	dBm
3DH3	-88	dBm
LE	-96	dBm

Table 13 Typical receiver sensitivity

11.3 Transmitter output power

Modulation type	Min	Typ	Max	Unit
BDR (1 Mbps)	10	12	14	dBm
EDR (2, 3 Mbps)	7	9	11	dBm
LE	7	9	11	dBm

Table 14 Transmitter output power at maximum setting

11.4 Carrier frequency accuracy

Parameter	Typ	Max	Bluetooth limit (total error)	Unit
Variation between individual units	3	10	+/- 25	ppm
Variation with temperature (-40 to +85°C)	9	15	+/- 25	ppm

Table 15 Carrier frequency accuracy

12 Physical dimensions

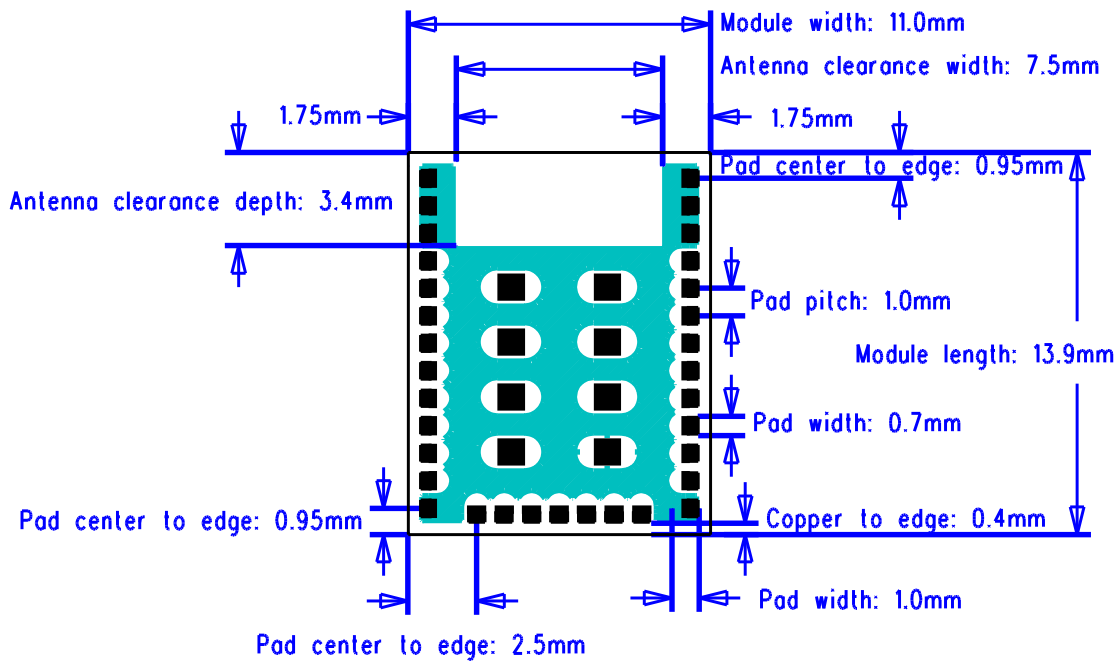

Figure 21 BT121 module physical dimensions

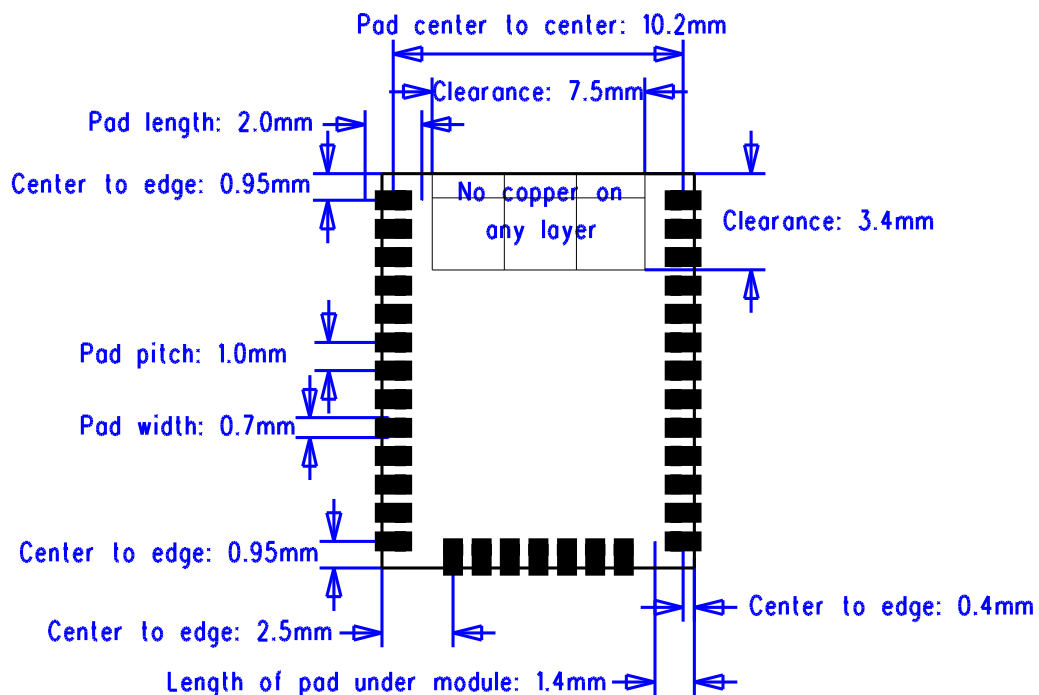

Figure 22 BT121 module recommended PCB pad pattern



The 8 center pins of the module are reserved for production programming and should be left unsoldered but despite of this unmasked traces and vias should NOT be placed under the module in order to prevent short circuits.

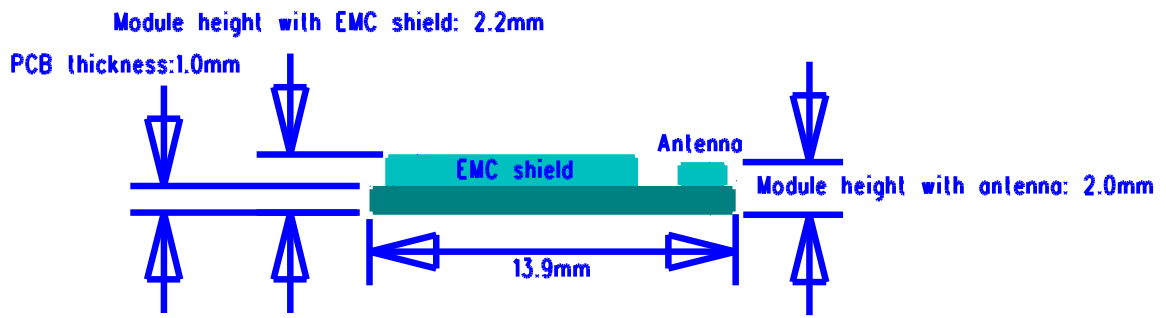

Figure 23 BT121 module side view dimensions

13 Soldering recommendations

Bluegiga *Bluetooth* Smart Ready module BT121 is compatible with the industrial standard reflow profile for Pb-free solders. The reflow profile to be used depends on the thermal mass of the entire populated application PCB, heat transfer efficiency of the oven and on the particular type of solder paste used. Consult the datasheet of the particular solder paste used for more detailed information regarding profile configurations.

The following recommendations for soldering the module are to ensure reliable solder joints and operation of the module after soldering. Since the soldering profile used is process and layout dependent, the optimum profile should be studied and decided case by case.

The following recommendation should be taken only as a starting point and should be adjusted according to more detailed instructions of the solder paste and soldering equipment manufacturers.

- Check the recommended soldering profile configuration from the solder paste manufacturers documentation.
- Avoid using more than one flow.
- Reliability of the solder joints and self-alignment of the component are dependent on the solder volume. A minimum stencil thickness of 150 μm is recommended.
- Aperture size of the stencil should be 1:1 with the pad size.
- A low residue, “no clean” solder paste should be used due to the low mounted height of the module.
- If the vias used on the application board have a diameter larger than 0.3 mm, it is recommended to mask the via holes at the module side to prevent solder wicking through the via holes. Solders have a habit of filling holes and leaving voids in the thermal pad solder junction, as well as forming solder balls on the other side of the application board. These phenomena can in some cases cause problems.

13.1 Soldering profile example

As an example of a typical soldering profile please see an example of a generic example of a reflow profile shown below. As stated in previous section soldering profiles are solder paste specific. Consult the manufacturer of the paste used.

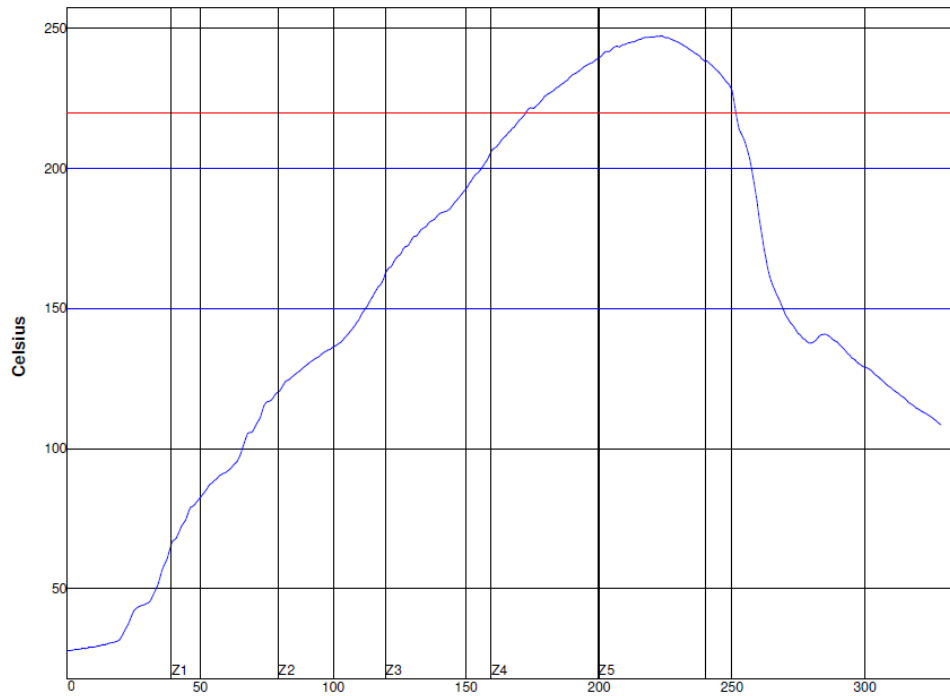

Figure 24 Reference reflow profile example

14 Tape and reel packaging

This section contains information regarding the tape and reel packaging and materials of packaging with dimensions for the Bluegiga *Bluetooth* Smart Ready BT121 module.

14.1 Reel material and dimensions

- Reel material PS Conductive Black – surface resistance 103 ↔ 105
- Reel diameter 13"
- Reel color Black

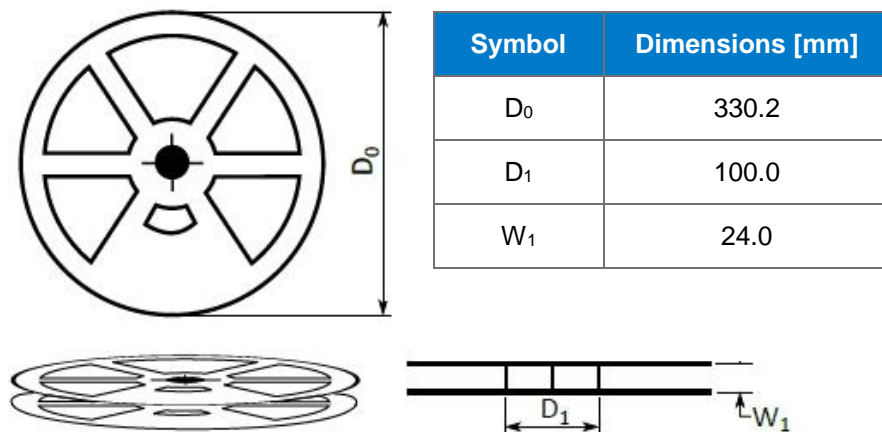

Table 16 Reel dimensions

14.2 Tape material and dimensions

- Tape material PS Conductive Black – surface resistance 103 ↔ 105

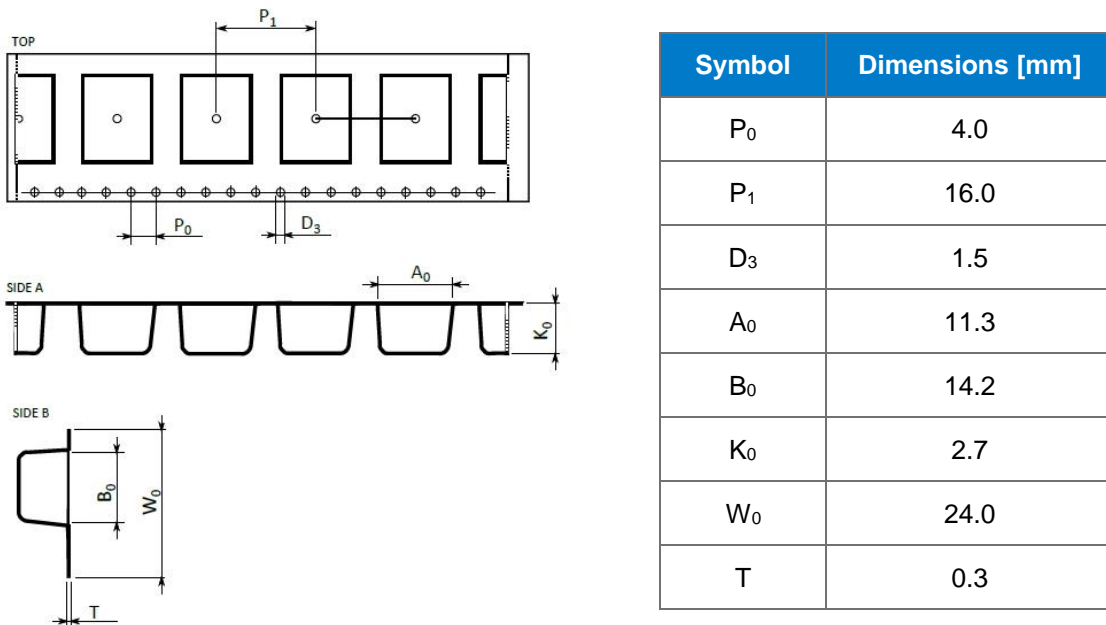
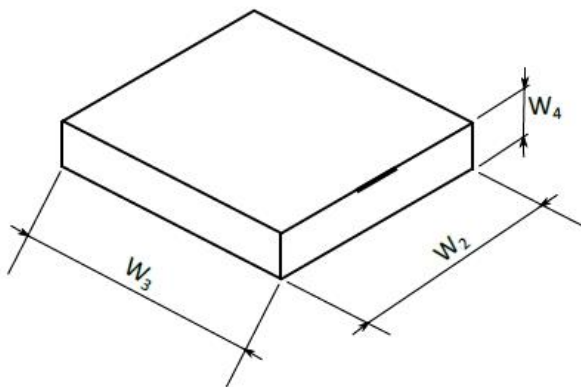

Table 17 Tape dimensions

14.3 Tape and reel box dimensions



Symbol	Dimensions [mm]
W ₁	338
W ₂	344
W ₃	44

Table 18 Tape and reel box dimensions

14.4 Module orientation in tape

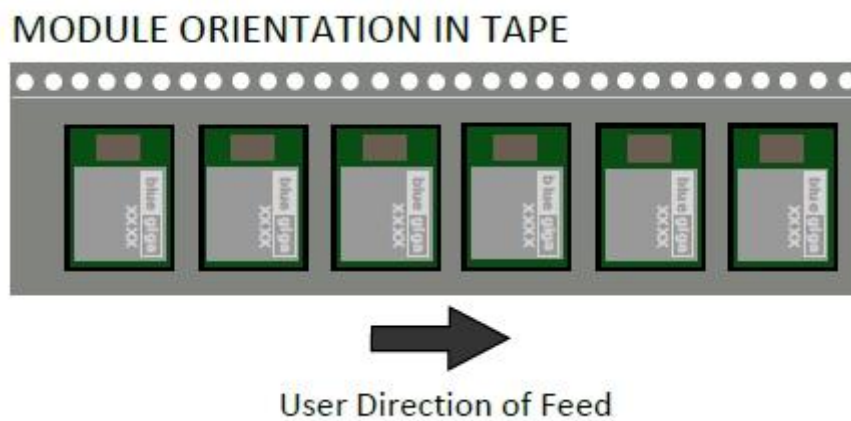

Figure 25 Module orientation in tape and feed direction

15 Certifications

BT121 compliance certifications are pending.

15.1 CE

BT121 is in conformity with the essential requirements and other relevant requirements of the R&TTE Directive (1999/5/EC). The product is conformity with the following standards and/or normative documents.

- EMC (immunity only) EN 301 489-17 V.1.3.2 in accordance with EN 301 489-1 V1.8.1
- Radiated emissions EN 300 328 V1.8.1

15.2 FCC and IC

This device complies with Part 15 of the FCC Rules. Operation is subject to the following two conditions:

- (1) this device may not cause harmful interference, and
- (2) this device must accept any interference received, including interference that may cause undesired operation.

FCC RF Radiation Exposure Statement

This equipment complies with FCC radiation exposure limits set forth for an uncontrolled environment. End users must follow the specific operating instructions for satisfying RF exposure compliance. This transmitter must not be co-located or operating in conjunction with any other antenna or transmitter. This transmitter is considered as mobile device and should not be used closer than 15 mm from a human body. Please contact www.bluegiga.com for detailed information.

IC Statements

This device complies with Industry Canada license-exempt RSS standard(s). Operation is subject to the following two conditions: (1) this device may not cause interference, and (2) this device must accept any interference, including interference that may cause undesired operation of the device.

Under Industry Canada regulations, this radio transmitter may only operate using an antenna of a type and maximum (or lesser) gain approved for the transmitter by Industry Canada. To reduce potential radio interference to other users, the antenna type and its gain should be so chosen that the equivalent isotropically radiated power (e.i.r.p.) is not more than that necessary for successful communication.

OEM Responsibilities to comply with FCC and Industry Canada Regulations

The BT121 Module has been certified for integration into products only by OEM integrators under the following conditions:

- The antenna(s) must be installed such that a minimum separation distance of 15 mm (FCC) / 20 mm (IC) is maintained between the radiator (antenna) and all persons at all times.
- The transmitter module must not be co-located or operating in conjunction with any other antenna or transmitter.

As long as the two conditions above are met, further transmitter testing will not be required. However, the OEM integrator is still responsible for testing their end-product for any additional compliance requirements required with this module installed (for example, digital device emissions, PC peripheral requirements, etc.).

IMPORTANT NOTE: In the event that these conditions cannot be met (for certain configurations or co-location with another transmitter), then the FCC and Industry Canada authorizations are no longer considered valid and the FCC ID and IC Certification Number cannot be used on the final product. In these circumstances, the OEM integrator will be responsible for re-evaluating the end product (including the transmitter) and obtaining a separate FCC and Industry Canada authorization.

End Product Labeling

The BT121 module is labeled with its own FCC ID and IC Certification Number. If the FCC ID and IC Certification Number are not visible when the module is installed inside another device, then the outside of the device into which the module is installed must also display a label referring to the enclosed module. In that case, the final end product must be labeled in a visible area with the following:

“Contains Transmitter Module FCC ID: QOQBT121”

“Contains Transmitter Module IC: 5123A-BGTBT121”

or

“Contains FCC ID: QOQBT121

“Contains IC: 5123A-BGTBT121”

The OEM integrator has to be aware not to provide information to the end user regarding how to install or remove this RF module or change RF related parameters in the user manual of the end product.

To comply with FCC and Industry Canada RF radiation exposure limits for general population, the antenna(s) used for this transmitter must be installed such that a minimum separation distance of 15 mm (FCC) / 20 mm (IC) is maintained between the radiator (antenna) and all persons at all times and must not be co-located or operating in conjunction with any other antenna or transmitter.

15.2.1 FCC et IC

Cet appareil est conforme à l'alinéa 15 des règles de la FCC. Deux conditions sont à respecter lors de son utilisation :

- (1) cet appareil ne doit pas créer d'interférence susceptible de causer un quelconque dommage et,
- (2) cet appareil doit accepter toute interférence, quelle qu'elle soit, y compris les interférences susceptibles d'entraîner un fonctionnement non requis.

Déclaration de conformité FCC d'exposition aux radiofréquences (RF):

Ce matériel respecte les limites d'exposition aux radiofréquences fixées par la FCC dans un environnement non contrôlé. Les utilisateurs finaux doivent se conformer aux instructions d'utilisation spécifiées afin de satisfaire aux normes d'exposition en matière de radiofréquence. Ce transmetteur ne doit pas être installé ni utilisé en concomitance avec une autre antenne ou un autre transmetteur. Ce transmetteur est assimilé à un appareil mobile et ne doit pas être utilisé à moins de 15 mm (FCC) / 20 mm (IC) du corps humain. Pour des informations détaillées, veuillez contacter le support technique Bluegiga : www.bluegiga.com.

Déclaration de conformité IC :

Ce matériel respecte les standards RSS exempt de licence d'Industrie Canada. Son utilisation est soumise aux deux conditions suivantes :

- (1) l'appareil ne doit causer aucune interférence, et
- (2) l'appareil doit accepter toute interférence, quelle qu'elle soit, y compris les interférences susceptibles d'entraîner un fonctionnement non requis de l'appareil.

Selon la réglementation d'Industrie Canada, ce radio-transmetteur ne peut utiliser qu'un seul type d'antenne et ne doit pas dépasser la limite de gain autorisée par Industrie Canada pour les transmetteurs. Afin de réduire les interférences potentielles avec d'autres utilisateurs, le type d'antenne et son gain devront être définis de telle façon que la puissance isotrope rayonnante équivalente (EIRP) soit juste suffisante pour permettre une bonne communication.

Les responsabilités de l'intégrateur afin de satisfaire aux réglementations de la FCC et d'Industrie Canada :

Les modules BT121 ont été certifiés pour entrer dans la fabrication de produits exclusivement réalisés par des intégrateurs dans les conditions suivantes :

- L'antenne (ou les antennes) doit être installée de façon à maintenir à tout instant une distance minimum de 15 mm (FCC) / 20 mm (IC) entre la source de radiation (l'antenne) et toute personne physique.
- Le module transmetteur ne doit pas être installé ou utilisé en concomitance avec une autre antenne ou un autre transmetteur.

Tant que ces deux conditions sont réunies, il n'est pas nécessaire de procéder à des tests supplémentaires sur le transmetteur. Cependant, l'intégrateur est responsable des tests effectués sur le produit final afin de se mettre en conformité avec d'éventuelles exigences complémentaires lorsque le module est installé (exemple : émissions provenant d'appareils numériques, exigences vis-à-vis de périphériques informatiques, etc.) ;

IMPORTANT : Dans le cas où ces conditions ne peuvent être satisfaites (pour certaines configurations ou installation avec un autre transmetteur), les autorisations fournies par la FCC et Industrie Canada ne sont plus valables et les numéros d'identification de la FCC et de certification d'Industrie Canada ne peuvent servir pour le produit final. Dans ces circonstances, il incombera à l'intégrateur de faire réévaluer le produit final (comprenant le transmetteur) et d'obtenir une autorisation séparée de la part de la FCC et d'Industrie Canada.

Étiquetage du produit final

Chaque module BT121 possède sa propre identification FCC et son propre numéro de certification IC. Si l'identification FCC et le numéro de certification IC ne sont pas visibles lorsqu'un module est installé à l'intérieur d'un autre appareil, alors l'appareil en question devra lui aussi présenter une étiquette faisant

référence au module inclus. Dans ce cas, le produit final doit comporter une étiquette placée de façon visible affichant les mentions suivantes :

« **Contient un module transmetteur certifié FCC QOQBT121** »

« **Contient un module transmetteur certifié IC 5123A-BGTBT121** »

ou

« **Inclut la certification FCC QOQBT121** »

« **Inclut la certification IC 5123A-BGTBT121** »

L'intégrateur est tenu de ne fournir aucune information à l'utilisateur final autorisant ce dernier à installer ou retirer le module RF, ou bien changer les paramètres RF du module, dans le manuel d'utilisation du produit final.

Afin de se conformer aux limites de radiation imposées par la FCC et Industry Canada, l'antenne (ou les antennes) utilisée pour ce transmetteur doit être installée de telle sorte à maintenir une distance minimum 15 mm (FCC) / 20 mm (IC) à tout instant entre la source de radiation (l'antenne) et les personnes physiques. En outre, cette antenne ne devra en aucun cas être installée ou utilisée en concomitance avec une autre antenne ou un autre transmetteur.

16 Ordering information

Product code	Description
BT121-A-V1	BT121 <i>Bluetooth</i> Smart Ready module with an integrated antenna
BT121-A-V1-iAP	BT121 <i>Bluetooth</i> Smart Ready module with an integrated antenna and Apple iAP profile. This part number is only available to Apple MFI licenses.
DKBT	Bluegiga <i>Bluetooth</i> Smart Ready Development kit

17 Contact Information

Sales: www.bluegiga.com

Technical Support: www.bluegiga.com/support

Orders: bluegiga-orders@silabs.com

WWW: www.bluegiga.com

SILICON LABS

Phone: +1 877.444.3032
400 West Cesar Chavez
Austin, TX 78701 USA

FINLAND OFFICE

Phone: +358 9 435 5060
Fax: +358 9 435 50660
Sinikalliontie 5A, 5th floor
02630 Espoo, Finland

Mouser Electronics

Authorized Distributor

Click to View Pricing, Inventory, Delivery & Lifecycle Information:

[Silicon Laboratories:](#)

[BT121-A-V2](#)