

## Digital MEMS microphones expansion board based on MP34DT01-M for STM32 Nucleo

Data brief

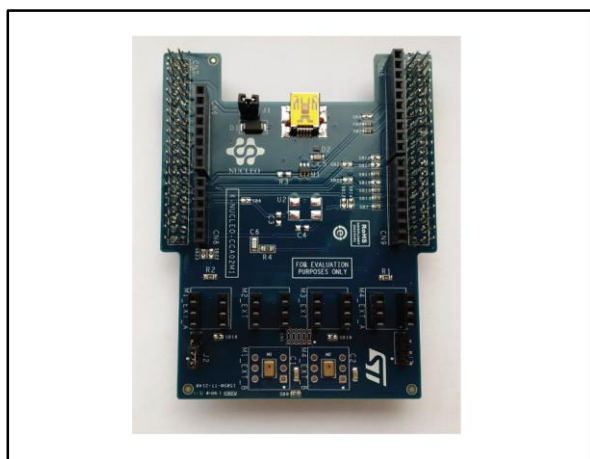

### Description

The X-NUCLEO-CCA02M1 is an evaluation board based on digital MEMS microphones. It is compatible with the Morpho connector layout, and it's designed around STMicroelectronics MP34DT01-M digital microphones. It has two microphones soldered on board and it is compatible with digital microphone coupon boards such as STEVAL-MKI129Vx and STEVAL-MKI155Vx. The X-NUCLEO-CCA02M1 allows the acquisition and streaming of up to 2 microphones using the I<sup>2</sup>S peripheral and up to 4 coupon microphones using both I<sup>2</sup>S and SPI. It represents an easy to use and fast solution for the development of microphone based application as well as a starting point for audio algorithm implementation.

### Features

- 2x MP34DT01-M Digital MEMS microphones on board
- 6 slots to plug digital microphone coupon boards such as STEVAL-MKI129Vx and STEVAL-MKI155Vx
- Up to 4 microphone synchronized acquisition and streaming
- Free comprehensive development firmware library and audio capture and USB streaming example application compatible with STM32Cube firmware
- Compatible with STM32 Nucleo boards
- Equipped with Morpho connector (upward and downward)
- Equipped with Arduino UNO R3 connector (upward) to allow multiple board application
- RoHS compliant

# 1 Schematic diagram

Figure 1: X-NUCLEO-CCA02M1 circuit schematic (Part 1)

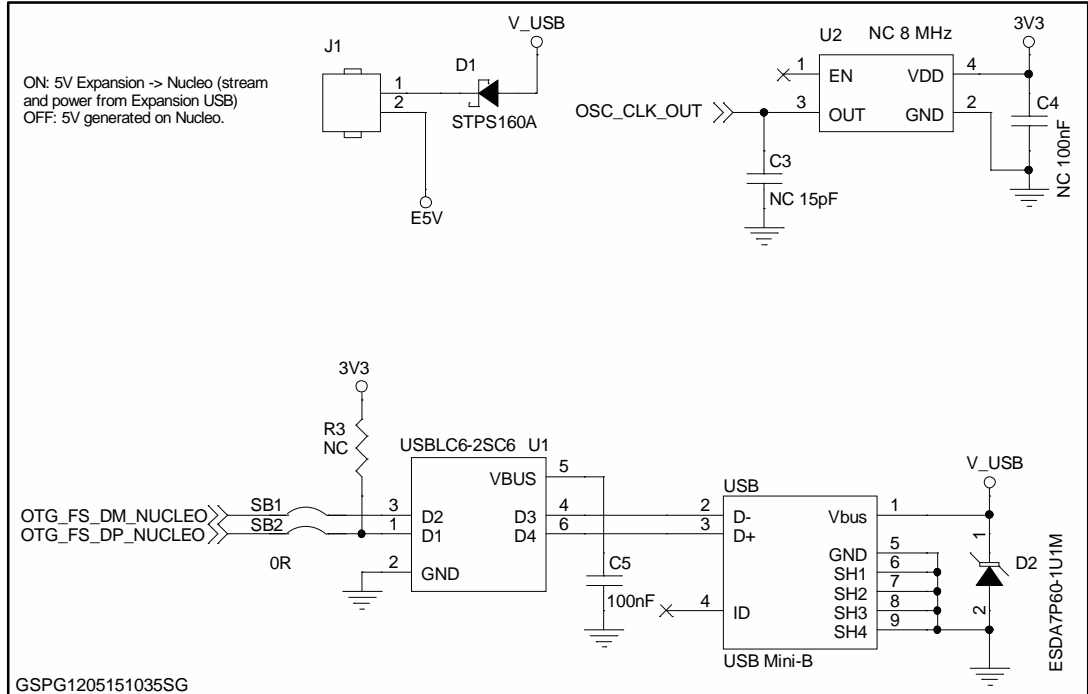

Figure 2: X-NUCLEO-CCA02M1 circuit schematic (Part 2)

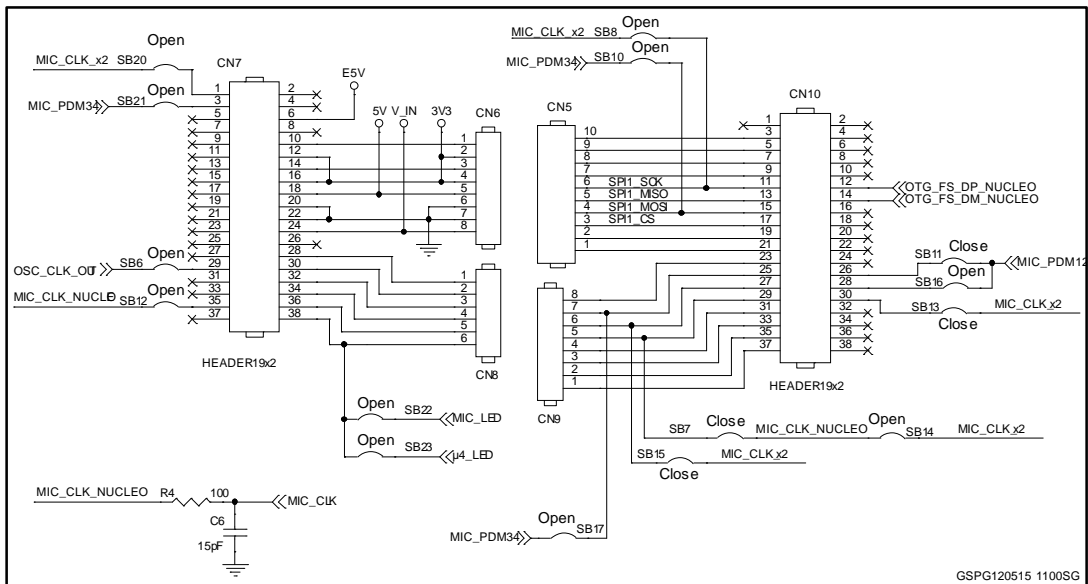

Figure 3: X-NUCLEO-CCA02M1 circuit schematic (Part 3)

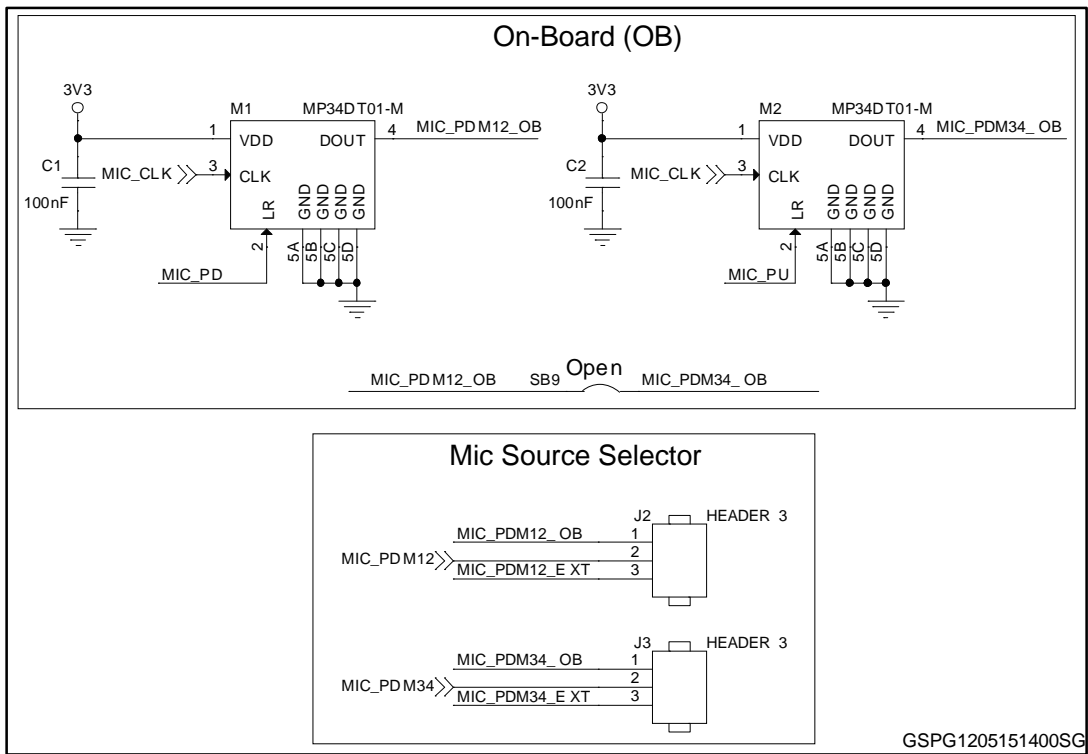
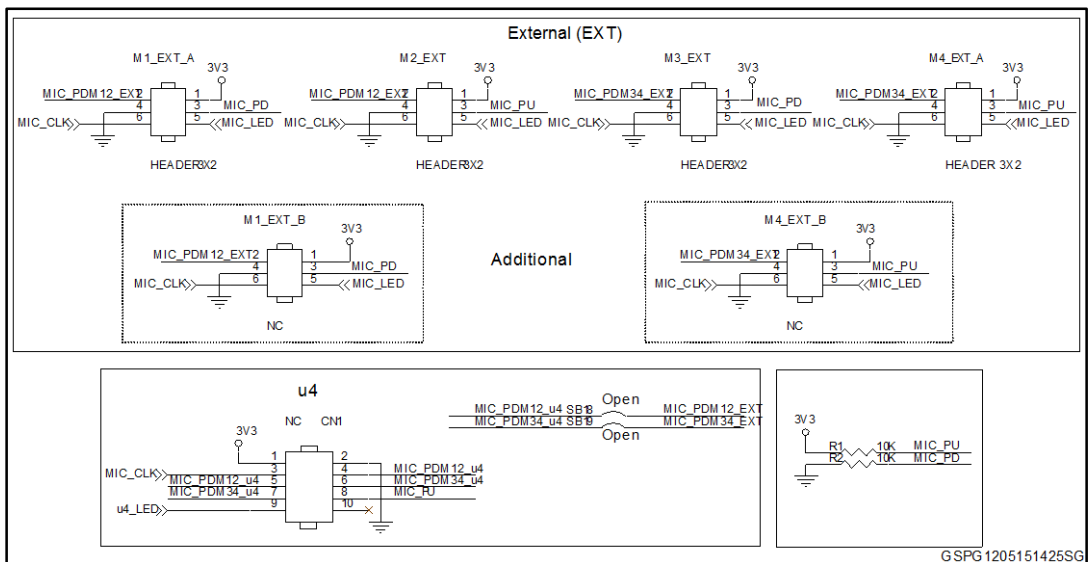

Figure 4: X-NUCLEO-CCA02M1 circuit schematic (Part 4)



## 2 Revision history

Table 1: Document revision history

Date	Version	Changes
13-May-2015	1	Initial release.

**IMPORTANT NOTICE – PLEASE READ CAREFULLY**

STMicroelectronics NV and its subsidiaries ("ST") reserve the right to make changes, corrections, enhancements, modifications, and improvements to ST products and/or to this document at any time without notice. Purchasers should obtain the latest relevant information on ST products before placing orders. ST products are sold pursuant to ST's terms and conditions of sale in place at the time of order acknowledgement.

Purchasers are solely responsible for the choice, selection, and use of ST products and ST assumes no liability for application assistance or the design of Purchasers' products.

No license, express or implied, to any intellectual property right is granted by ST herein.

Resale of ST products with provisions different from the information set forth herein shall void any warranty granted by ST for such product.

ST and the ST logo are trademarks of ST. All other product or service names are the property of their respective owners.

Information in this document supersedes and replaces information previously supplied in any prior versions of this document.

© 2015 STMicroelectronics – All rights reserved

# Mouser Electronics

Authorized Distributor

Click to View Pricing, Inventory, Delivery & Lifecycle Information:

[STMicroelectronics:](#)

[X-NUCLEO-CCA02M1](#)