

Energy storage - UPS-BAT/LI-ION/24DC/120WH - 2320351

Please be informed that the data shown in this PDF Document is generated from our Online Catalog. Please find the complete data in the user's documentation. Our General Terms of Use for Downloads are valid (<http://phoenixcontact.com/download>)



Energy storage device, LI-ION technology, 24 V DC, 120 Wh, for ambient temperatures of -20°C ... 60°C, automatic detection and communication with QUINT UPS-IQ

Product Description

For continuous monitoring and intelligent management, there is constant communication with the QUINT UPS. Thanks to automatic detection of the energy storage, and tool-free switching during operation, quick installation is possible. The QUINT UPS with IQ technology energy storage leaves the warehouse fully charged.

Your advantages

- ✓ Long service life with long buffer times
- ✓ Lithium iron phosphate technology
- ✓ High energy density



Key Commercial Data

Packing unit	1 pc
GTIN	 4 046356 599054
GTIN	4046356599054
Weight per Piece (excluding packing)	2,900.000 g
Custom tariff number	85076000
Country of origin	China

Technical data

Dimensions

Width	135 mm
Height	202 mm
Depth	110 mm

Ambient conditions

Degree of protection	IP20
Ambient temperature (operation)	-20 °C ... 58 °C

Energy storage - UPS-BAT/LI-ION/24DC/120WH - 2320351

Technical data

Ambient conditions

Ambient temperature (storage/transport)	-40 °C ... 65 °C
Max. permissible relative humidity (operation)	≤ 80 %
Degree of pollution	2

Input data

Nominal input voltage	24 V DC
Buffer period	14 min. (20 A)

Output data

Nominal output voltage	24 V DC
Output current I _{max}	30 A
Connection in parallel	3
Connection in series	No
Output fuse	1x 30 A ATOF 32V (breaking capacity 1000 A)

General

IQ technology	Yes
Disposal	Used batteries must not be thrown away with household waste, they should instead be disposed of in accordance with applicable national regulations. They can also be returned to Phoenix Contact or the manufacturer.
Net weight	2.9 kg
Memory medium	LI-ION, 120 Wh
Protection class	III
Degree of protection	IP20
Mounting position	horizontal DIN rail NS 35, EN 60715

Standards

Standard - Electrical safety	EN 60950-1/VDE 0805 (SELV)
Standard – Electronic equipment for use in electrical power installations and their assembly into electrical power installations	EN 50178/VDE 0160 (PELV)

Conformance/approvals

UL approvals	UL/C-UL listed UL 508
	UL/C-UL Recognized UL 60950-1
	UL ANSI/ISA-12.12.01 Class I, Division 2, Groups A, B, C, D (Hazardous Location)

Drawings

Energy storage - UPS-BAT/LI-ION/24DC/120WH - 2320351

Block diagram

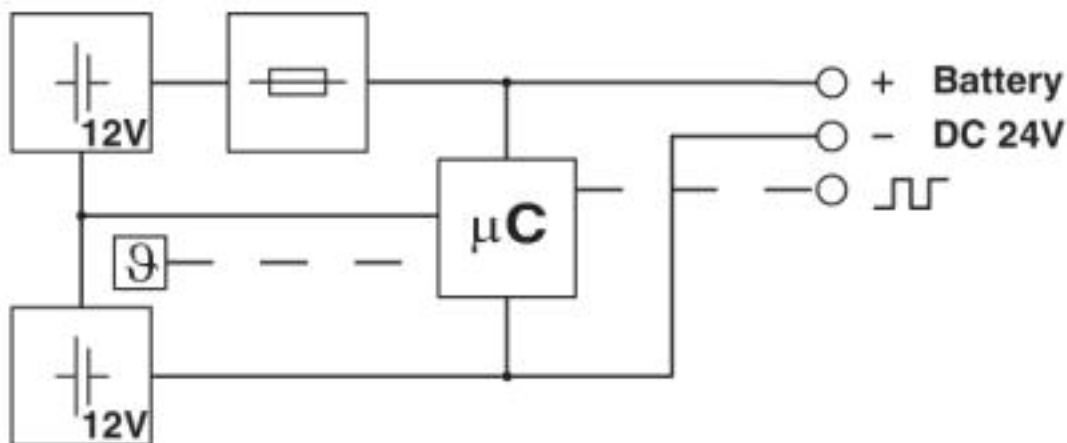

Classifications

eCl@ss

eCl@ss 10.0.1	27050403
eCl@ss 4.0	27040600
eCl@ss 4.1	27040600
eCl@ss 5.0	27040600
eCl@ss 5.1	27040600
eCl@ss 6.0	27040600
eCl@ss 7.0	27050403
eCl@ss 8.0	27050403
eCl@ss 9.0	27050403

ETIM

ETIM 2.0	EC000382
ETIM 3.0	EC000382
ETIM 4.0	EC000357
ETIM 5.0	EC000357
ETIM 6.0	EC000357
ETIM 7.0	EC000357

UNSPSC

UNSPSC 6.01	30211510
UNSPSC 7.0901	39121011
UNSPSC 11	39121011
UNSPSC 12.01	39121011
UNSPSC 13.2	26111715
UNSPSC 18.0	26111715
UNSPSC 19.0	26111715
UNSPSC 20.0	26111715

Energy storage - UPS-BAT/LI-ION/24DC/120WH - 2320351

Classifications

UNSPSC

UNSPSC 21.0	26111715
-------------	----------

Approvals

Approvals

Approvals

UL Listed / UL Recognized / cUL Recognized / cUL Listed / EAC / cULus Recognized / cULus Listed

Ex Approvals

UL Listed / cUL Listed / cULus Listed

Approval details

UL Listed		http://database.ul.com/cgi-bin/XYV/template/LISEXT/1FRAME/index.htm	FILE E 123528
-----------	--	---	---------------

UL Recognized		http://database.ul.com/cgi-bin/XYV/template/LISEXT/1FRAME/index.htm	FILE E 211944
---------------	--	---	---------------

cUL Recognized		http://database.ul.com/cgi-bin/XYV/template/LISEXT/1FRAME/index.htm	FILE E 211944
----------------	--	---	---------------

cUL Listed		http://database.ul.com/cgi-bin/XYV/template/LISEXT/1FRAME/index.htm	FILE E 123528
------------	--	---	---------------

EAC		EAC-Zulassung
-----	--	---------------

cULus Recognized	
------------------	--

cULus Listed	
--------------	--

Energy storage - UPS-BAT/LI-ION/24DC/120WH - 2320351

Accessories

Accessories

Assembly adapter

Assembly adapters - QUINT-ADAPTER/4 - 2866857

Assembly adapter for QUINT-BAT/24DC... on 35mm rail



Fuse

Fuse - SI FORM C 25 A DIN 72581 - 0913757



Flat-type plug-in fuse, type C, color code: white, nominal current: 25 A

Fuse - FUSE 30A/32V ATOF - 2908365



Fuse, nominal current: 30 A. Length: 19.1 mm, width: 5 mm, height: 18.8 mm